

Tandy Radio Shack TRS-80 (Model I) 8 bit Personal Computer

I visited west coast of USA (Los Angeles and San Francisco, CA) as honeymoon from April to May spending so-called "Golden week (consecutive holidays from April 29 to May 5)" in 1978. I rented a car and drove it to go to many places I wished to visit in both LA (Disneyland, Universal Studios, Sea World, etc.) and SF (Golden Gate, Coit Tower, Great America, Mystery Spot, etc.).

When strolling in San Francisco downtown, I encountered the TRS-80 personal computer displayed in showcase of a Tandy Radio Shack (TRS) store seeing through the window from pedestrian way. The price tag was unforgettable \$599 (Equivalent to \$3,000 now due to inflation accumulated for last 46 years and the exchange rate was 240 yen/\$. Accordingly, the sales price was 720,000 yen (72 万円)). Over \$1,000 US dollars was still in my wallet. TRS-80 was saying "Get me, get me...." and it was actually affordable to be in my hands. There were a lot of Radio Shack stores in SF at that time although the number of Radio Shack stores are declining nowadays. All of Radio Shack stores displayed and promoted TRS-80 as an epoch-making product. Design team members of IBM PC which debuted in August 1981 must have studied the design approach of TRS-80 as a predecessor.

In early morning just before flying back to Japan, I visited a Radio Shack store just opened the door near Macy's department store at San Francisco downtown and bought a TRS-80 Model I (first generation). A store manager recommended purchasing an Expansion Interface box and a Level II BASIC ROM which was under development. I additionally paid for both the devices along with international shipping fee to Japan. I'm rich!



TRS-80 Main Keyboard



TRS-80 Expansion Interface

Because they were treated as direct imported products from USA, I was ordered to appear Tokyo Customs at Baraki Chiba prefecture far from my home (Kawasaki Kanagawa prefecture), paid duty that a custom officer declared without certain basis, and had to take the item out of bond warehouse. I had to do this procedure twice every time the item arrived Japan. What an outdated inefficient country, Japan!

I bought a Hitachi black and white 12" CRT monitor for 50,000 yen at Akihabara Tokyo, a world famous electronics junk yard in Japan, and TRS-80 worked beautifully even in Japan. Probably, I was one of very few people in Japan who owned a personal computer at that moment.

Next, I was strongly inspired obtaining a 5.25 inch floppy disk drive with a TRS-80 disk operation system disk that can be driven by Western Digital floppy disk controller LSI ([FD1771](#)) assembled in TRS-80 Expansion Interface box. I bought it at Radio Shack Japan store located at western suburb of Tokyo. However, it frequently made read errors and did not work properly at initial stage. The cause was AC frequency difference of 50Hz in Tokyo Japan and 60Hz in USA. A TRS-80 system disk made in USA (60Hz) made read errors on a floppy disk drive running in Tokyo Japan (50Hz). There was AC frequency dependency appeared on the very early stage of floppy disk drive made by Shugart.

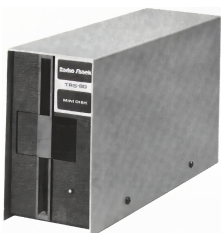

TRS-80 5.25 inch Floppy Disk Drive (MINI DISK)

I brought the complete TRS-80 system into NEC and demonstrated. This triggered the 8 bit personal computer development in NEC.

As Textbook for [NEC PC8001](#)

At that time, NEC personal computer interest group (people mainly split off from Automation System Promotion department (自動化推進部), IC division (集積回路事業部) at Tamagawa plant (玉川事業場)) lead by Kazuya Watanabe (渡辺和也) together with Tomio Goto (後藤富雄) et al. who had successfully designed [TK-80](#) were eagerly plotting to develop a 8 bit personal computer as a next major product. Their targeted PC model was Apple II at the beginning. I disagreed to target Apple II and recommended TRS-80 instead, because the main application of the Apple II was video games with low resolution (280 x 192). I insisted that a future NEC 8 bit personal computer must be a business machine, not a game machine.

Just before I went to California USA to have a [μPD7220 \(GDC\) kick off meeting at Intel](#) in the middle of December 1978, Goto-san came in and requested me to purchase TRS-80 schematics and technical information books already published and sold at Radio Shack store. I rode on a complimentary airport limousine bus from San Francisco Airport (SFO) to Macy's department store and purchased the two books at the same Radio Shack store I bought my TRS-80. I handed the two books to them after returning Japan. Of course, I kept one more set for my own use.

Beforehand, NEC Fuchu Peripheral Equipment division (府中端末装置事業部) had developed [μPD3301 CRTC](#) (Reverse engineering of Intel [8275 CRTC expanding row buffer and FIFO size bigger](#) to make 7 bits coding to 8 bits). Because I had taken charge of the functional evaluation, I introduced and lectured about μPD3301 CRTC to Goto-san's group as well. μPD3301 CRTC needs to get display data stored on main memory by DMA (Direct Memory Access) handled by [μPD8257 DMAC](#) (Reverse engineering of Intel 8257 DMAC) every display frame time. Such DMA data transfer slows CPU processing speed a lot because CPU processing stops all the time the DMA is asserted. I pointed out the fatal drawback but they adopted and implemented both μPD3301 and μPD8257 on PC8001.

This resulted in a major defect of PC8001.

BASIC interpreter was indispensable being implemented on personal computer at that time but it had to be a sufficient set of BASIC interpreter unlike a cheap subset implemented on TK80BS. Microsoft had already achieved an actual result of providing BASIC interpreter to Tandy TRS-80. NEC requested Microsoft to provide a BASIC interpreter getting a help from ASCII VP Kay Nishi (西和彦), VP Asian regional Marketing of Microsoft, most importantly a close friend of Bill Gates of Microsoft founder. Then, the Microsoft BASIC interpreter was implemented on PC8001. But the screen result after boot-up always displayed a shameful message for NEC as below.

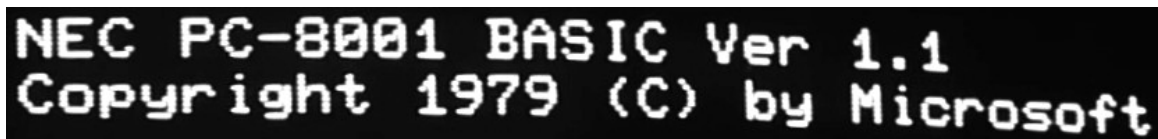

```
NEC PC-8001 BASIC Ver 1.1
Copyright 1979 (C) by Microsoft
```

TRS-80 implemented 4116 [16 kbit DRAMs](#) as main memory (Main Keyboard installs 16kB and Extension Interface box installs 32kB; The grand total is 48kB). PC8001 implemented 32kB main memory (16 pieces of 16 kbit DRAMs).

Until then, Goto-san's group did not have any expertise of utilizing DRAMs that requires RAS/CAS DRAM specific memory timing and refresh address control (only had a SRAM control expertise like other developers). Z80 CPU (Running at 1.774MHz (10.6445MHz divided by 6 done by 74LS92, see schematics attached)) itself was able to generate the 7 bit RAS only refresh address (patented by Zilog; not effective for 64kbit or bigger size DRAMs). By referring to TRS-80 schematics, DRAMs along with the DRAM control logic using the same [Z80 CPU](#) (NEC [μPD780](#); reverse engineering of Zilog Z80) were successfully implemented on PC8001.

NEC was good at reverse engineering (Takeoff, 物まね) of LSIs designed by foreign companies such as Fairchild, Texas Instrument, Intel, and Zilog. Most LSIs which was said to be designed by NEC IC division were originated from architectural designs by NEC in-house divisions such as Fuchu, Central research, and Abiko except desk-top calculator LSIs, 4 bit and 8 bit single-chip microprocessors, and graphics LSIs such as [μPD7220/72120](#). Such takeoff was not sustainable, did not spawn creativity and true ability, and made siege mentality eventually.

As mentioned above, they started the design of NEC PC8001 referring to the TRS-80 related books in December, 1978 and released in April, 1979. So quick. It was a dawn of personal computer era in Japan. Congratulations!

μPD7220 GDC Breadboard Debugger

When I designed μPD7220 GDC, I applied the TRS-80 as a breadboard debugger and software programmer. Refer to Page 1 of "[jeff_wise.pdf](#)".

IBM PC started using ISA (Industry Standard Architecture) bus in 1981. Before the appearance of IBM PC, TRS-80 used own TRS bus connected between Main Keyboard and Expansion Interface box.

I simply took the bus signals shown **red** at the table below from TRS bus and connected to μPD7220 breadboard/demonstration/evaluation boards.

Refer to Page 8 (Demonstration board schematics) of "[TG_7220_all.pdf](#)".

TRS Bus							
Pin #	Signal	Pin #	Signal	Pin #	Signal	Pin #	Signal
1	RAS/	11	A8	21	INT/	31	A4
2	SYSRES/	12	OUT/ (IOWR/)	22	D1	32	D2
3	CAS/	13	WR/ (MWR/)	23	TEST/	33	WAIT/
4	A10	14	INTAK/	24	D6	34	A3
5	A12	15	RD/ (MRD/)	25	A0	35	A5
6	A13	16	MUX	26	D3	36	A7
7	A15	17	A9	27	A1	37	<GND>
8	<GND>	18	D4	28	D5	38	A6
9	A11	19	IN/ (IORD/)	29	<GND>	39	<GND>
10	A14	20	D7	30	D0	40	A2

For functional debug of μPD7220, I wrote a BASIC language program interpreted real time by Microsoft BASIC interpreter integrated on Level II ROM installed on TRS-80 Main Keyboard.

For demonstration of μPD7220, I wrote a Z80 assembly language program assembled by Z80 assembler and linker running on TRS-80 because faster processing speed was fundamental.

Refer to Page 23 to 25 (Assemble source code of the μPD7220 demonstration program) of "[TG_7220_all.pdf](#)".

NEC PC9801

Fuchu Computer Technology Headquarters (府中コンピュータ技術本部) PC9801 design group lead by Kaoru Tosaka (戸坂馨) together with Kiyotaka Matsubara (松原清隆) et al. started designing 16 bit personal computer PC9801 in October 1981, and released it one year later.

Fuchu made a clear decision to adopt two pieces of μ PD7220 GDC (one for character display and another for graphics display like [NEC N5200 APC](#) implemented one year earlier) kicking out μ PD3301 CRTC that Goto-san's group recommended at Fuchu versus Tamagawa joint meeting held at Fuchu plant.

Furthermore, Fuchu Fundamental Software department (府中基本ソフトウェア部) dumped Microsoft BASIC interpreter implemented on PC8001 and newly started designing a genuine upgraded NEC BASIC interpreter keeping backward compatibility for Microsoft Basic interpreter installed on PC8001.

```
NEC N-88 BASIC(86) version 2.0
Copyright (C) 1983 by NEC Corporation / Microsoft Corp.
```

They resulted in great success of PC9801 in Japan.

Display resolution of PC9801 was defined as 640 x 400 to save the number of display memory DRAMs to be installed to a half of [640 x 480 \(VGA\)](#) or [800 x 600 \(SVGA\)](#), IBM PC adopted later on. This incurred the following problems.

- (1) A circle was displayed as a vertically extended ellipse on a regular CRT monitor display which aspect ratio is 4:3. It happened on an image printer as well. (Resolved by hidden software solution)
- (2) Most LCD flat panel vendors hesitated to manufacture 640 x 400 physical size panel because manufacturing of 640 x 480 or larger panel size was already a technical trend. NEC flat panel manufacturing group was unable to make 640 x 400 flat panels sustainable for mass production.

	NEC PC9801	IBM PC
Display resolution	640 x 400	640 x 480 (VGA) 800 x 600 (SVGA) 1024 x 768 (XGA)
Aspect Ratio	4:2.5	4:3
Display memory capacity	64 MB (640 x 400 x 4)	128 MB (800 x 600 x 4)

Eventually, PC9800 notebook design and manufacturing failed.

Although the graphics display resolution of PC9801 stayed the same (640 x 400) for a long time, the one of IBM PC had evolved so quickly. The market share position changed drastically.

Due to the facts above, PC9801 was rapidly replaced by IBM PC (both desktop and notebook) in Japan in around 1995.

The appearance of Microsoft Windows 95 for IBM PC was a "coup de grace" for PC9801. The survival battle was over.

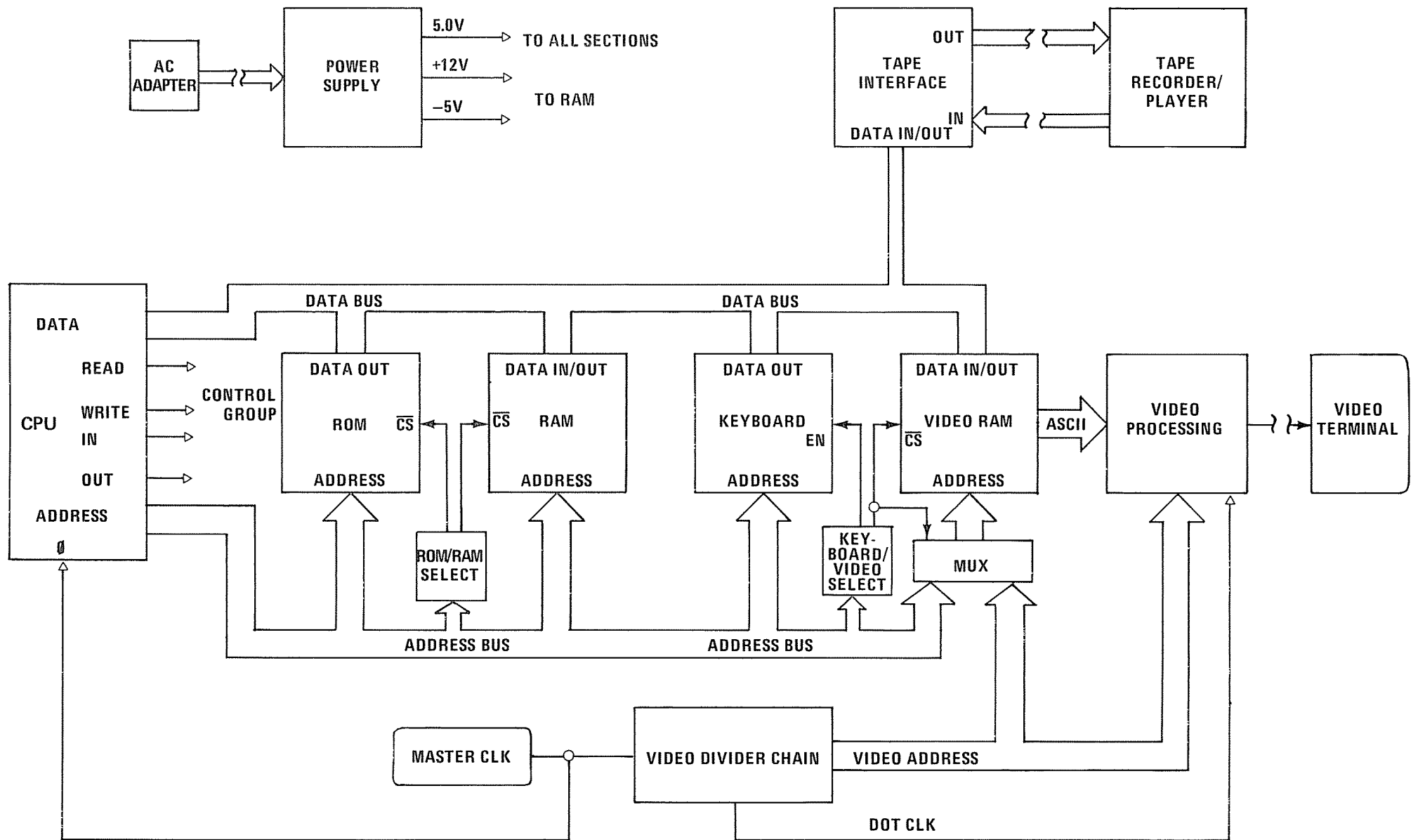

TRS-80 Main Keyboard Block Diagram

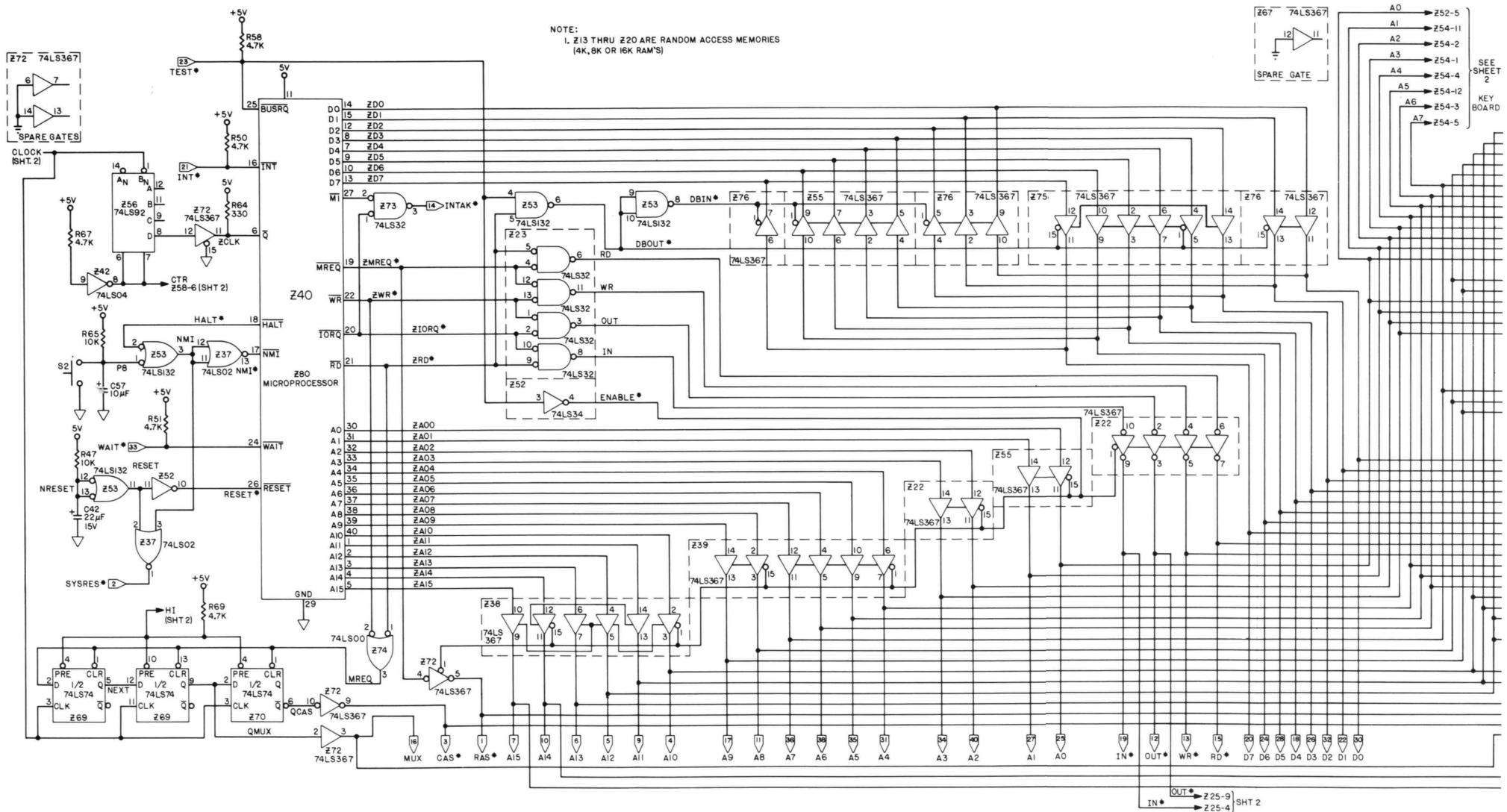

TRS-80 Main Keyboard Sheet 1 (Left)

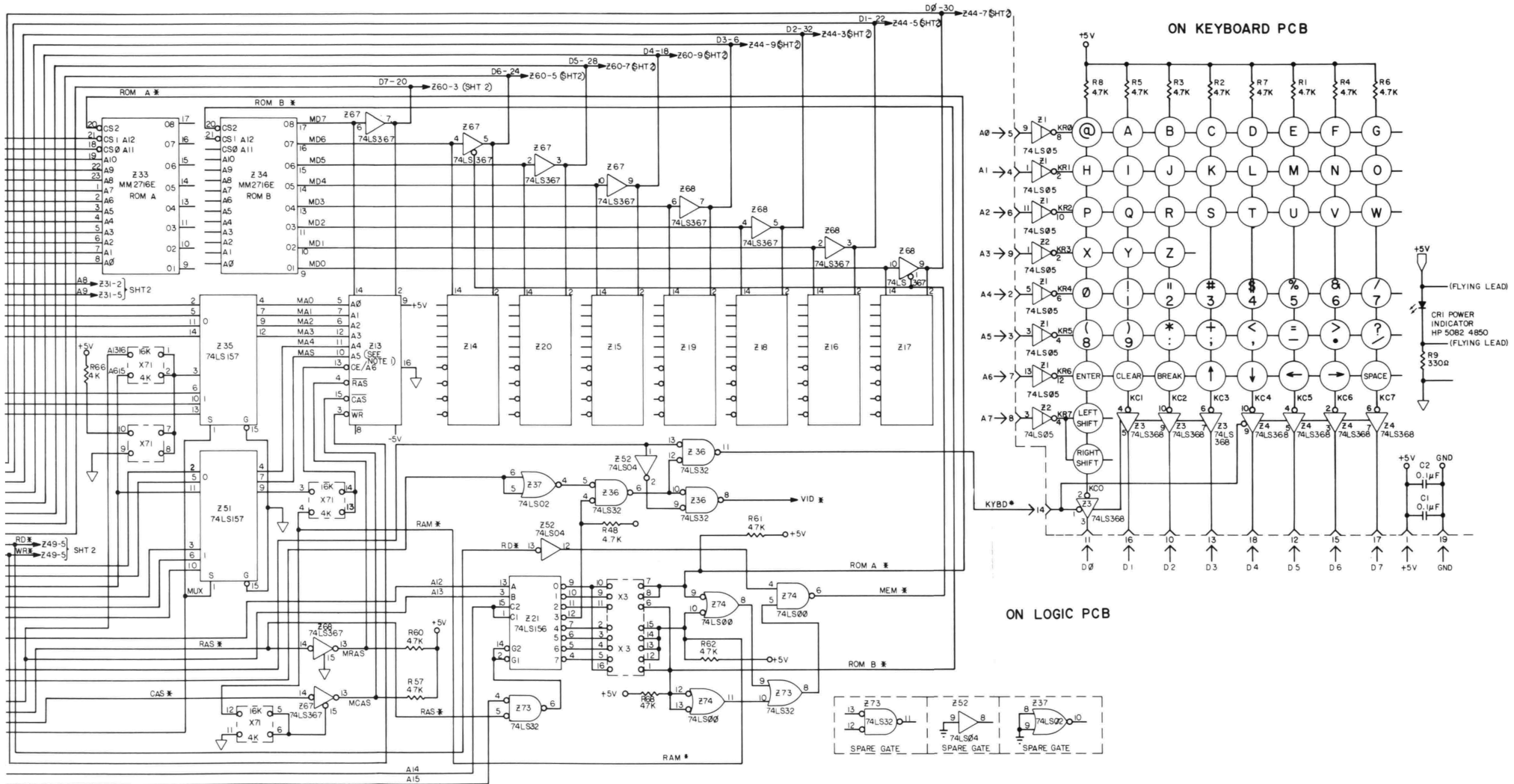

TRS-80 Main Keyboard Sheet 1 (Right)

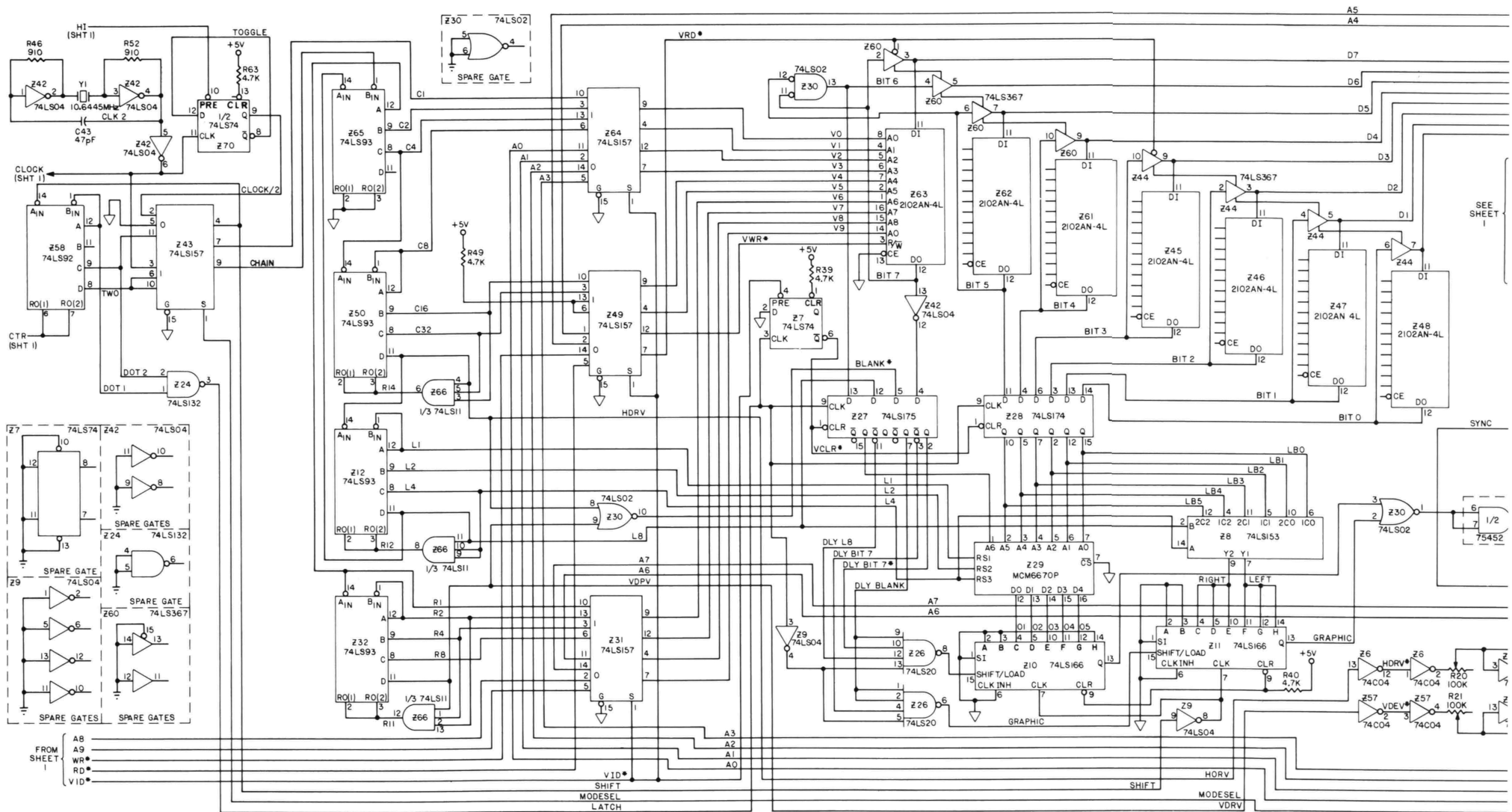

TRS-80 Main Keyboard Sheet 2 (Left)

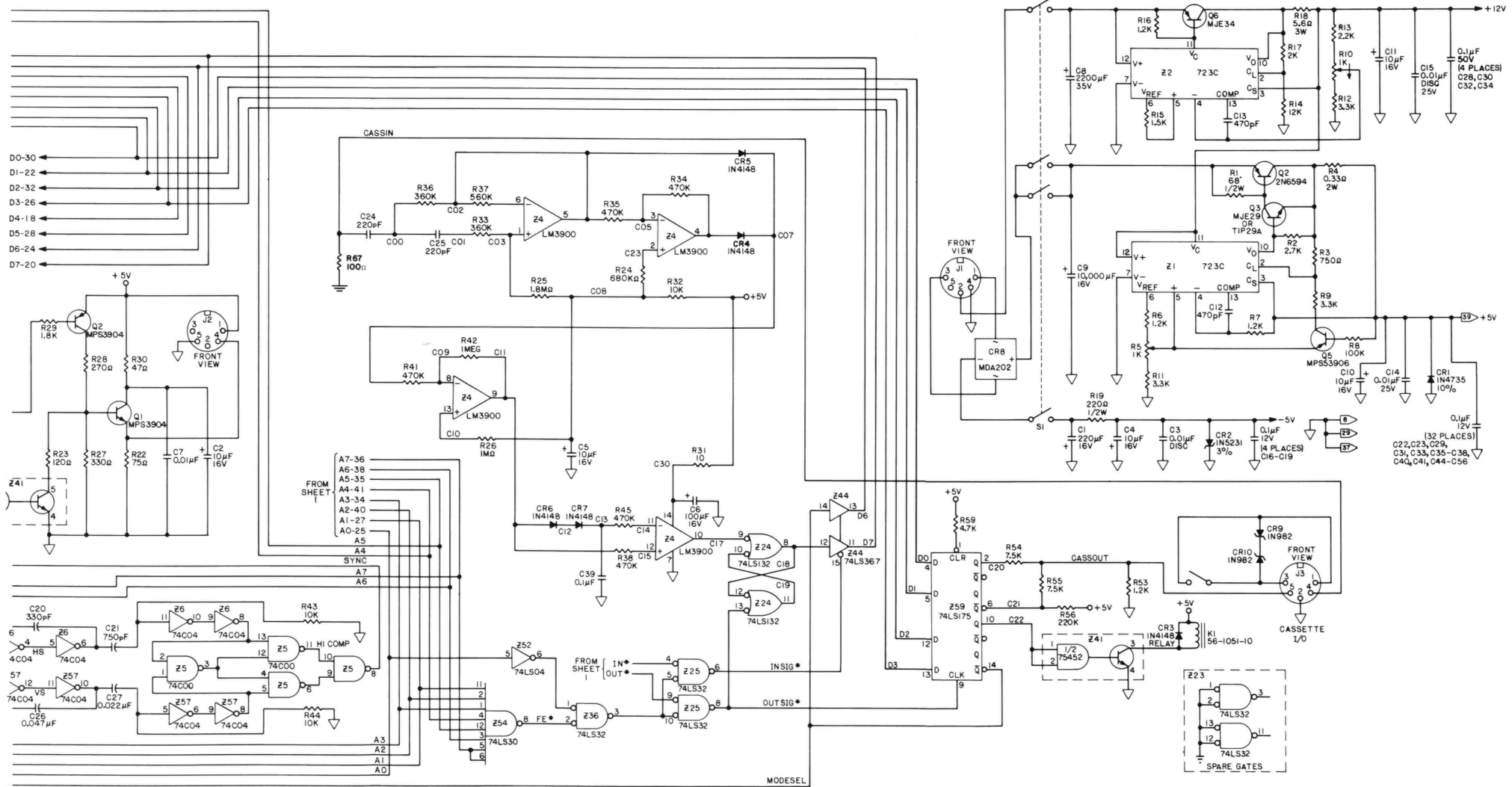

TRS-80 Main Keyboard Sheet 2 (Right)

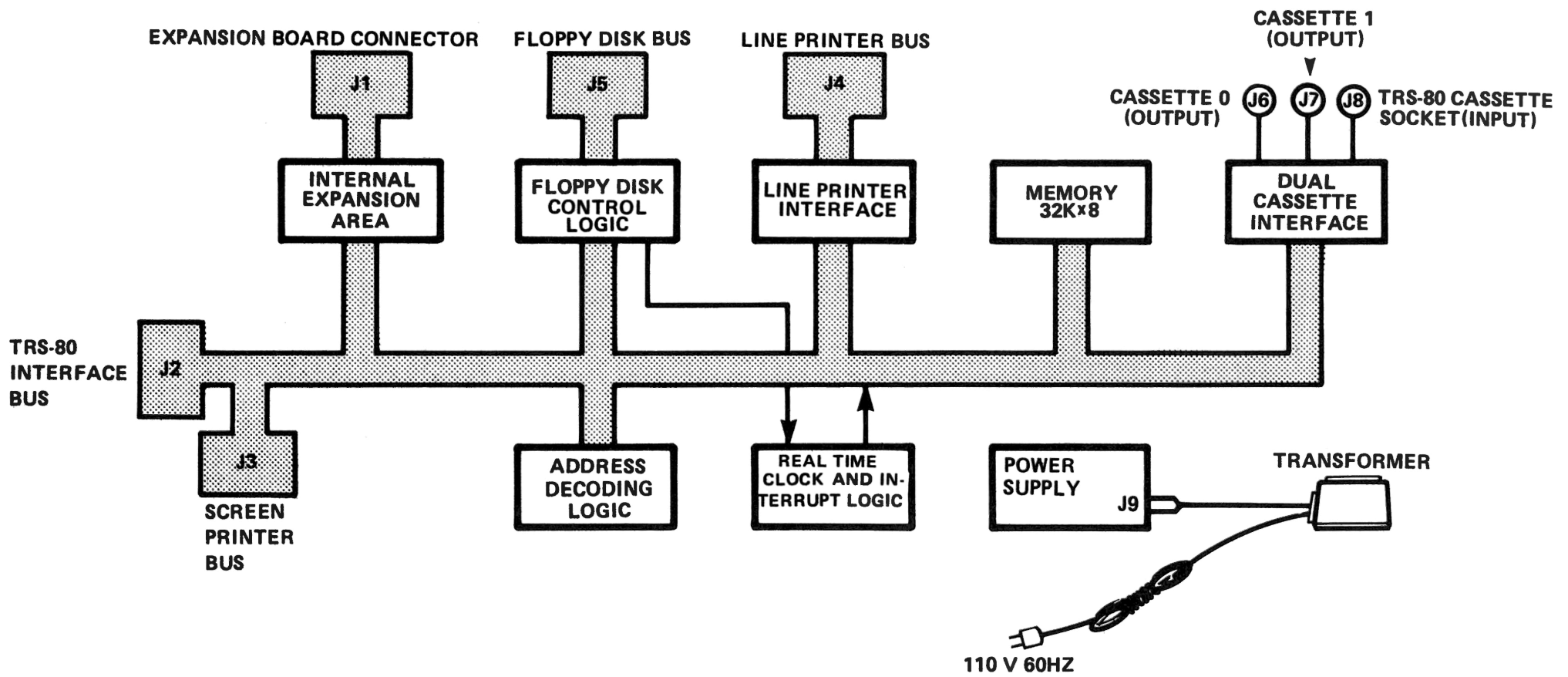

TRS-80 Expansion Interface Block Diagram

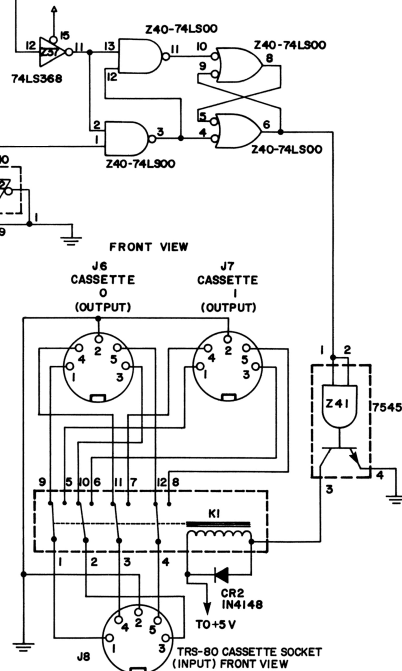
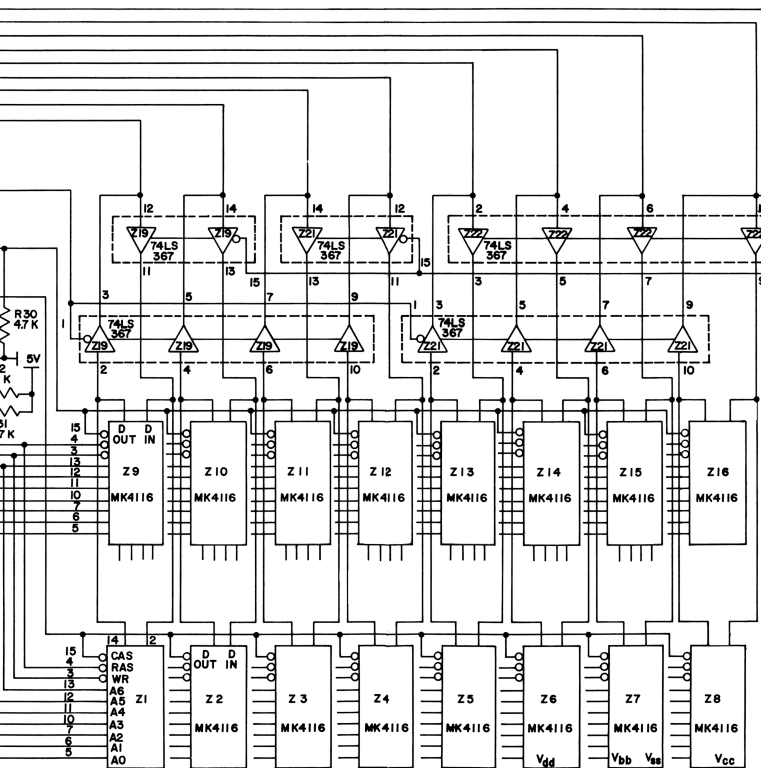
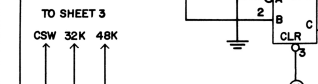
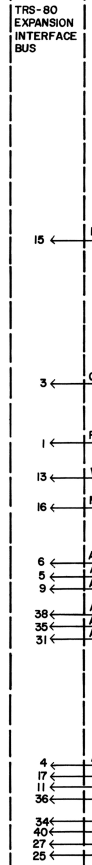
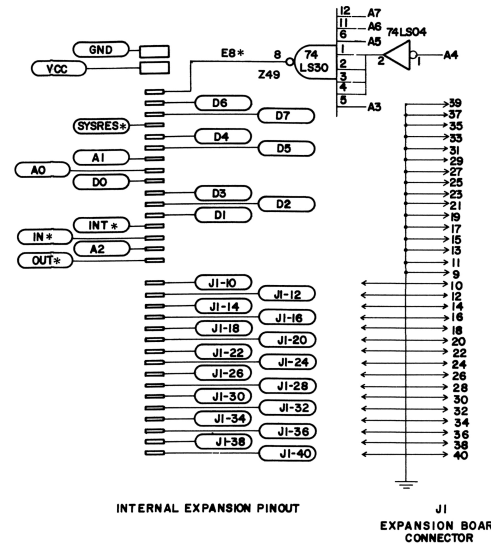
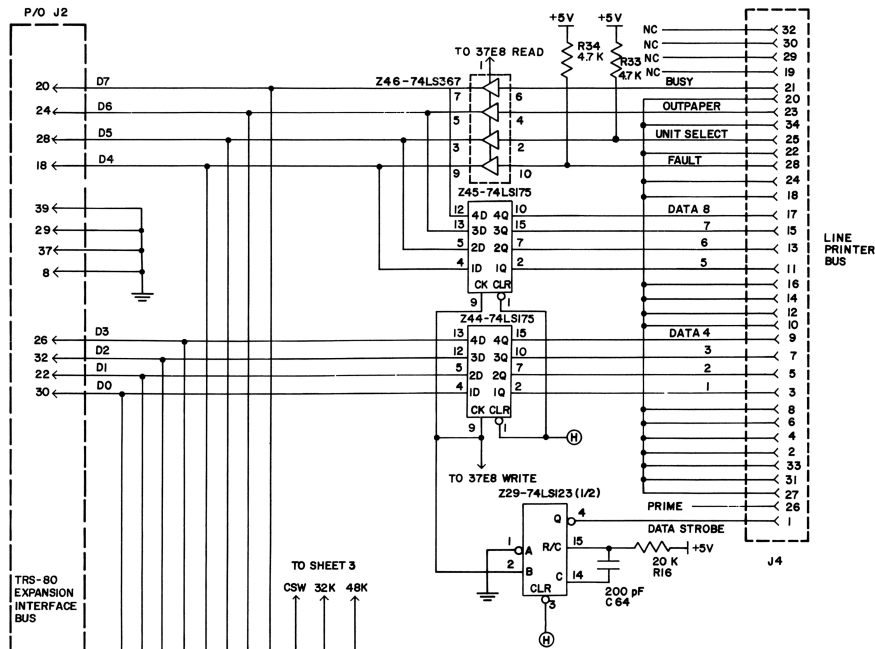

- NOTES: UNLESS OTHERWISE INDICATED:
- 1.) ALL CAPACITORS ARE IN PICOFARADS, 10%.
 - 2.) ALL RESISTORS ARE IN OHMS, 1/4 WATT, 10%. K=1000.
 - 3.) ALL RAMS(MK4116) ARE IN 16 PIN SOCKETS.
 - 4.) PINS 1,3,4,5,6,7,8,9,10,11,12,13 AND 16 OF ALL RAMS ARE TIED IN PARALLEL.
 - 5.) (H) DENOTES LOGICAL LEVEL 1.

TRS-80 Expansion Interface Sheet 1

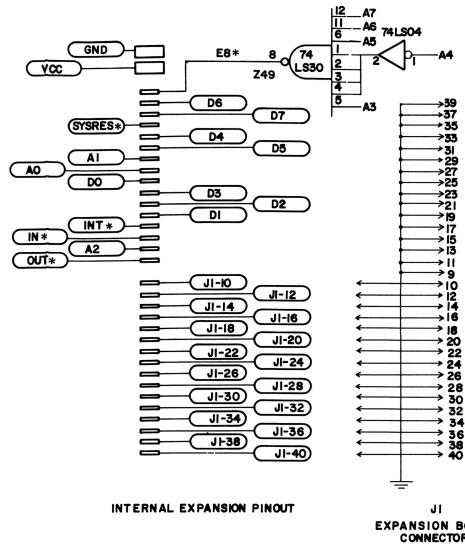
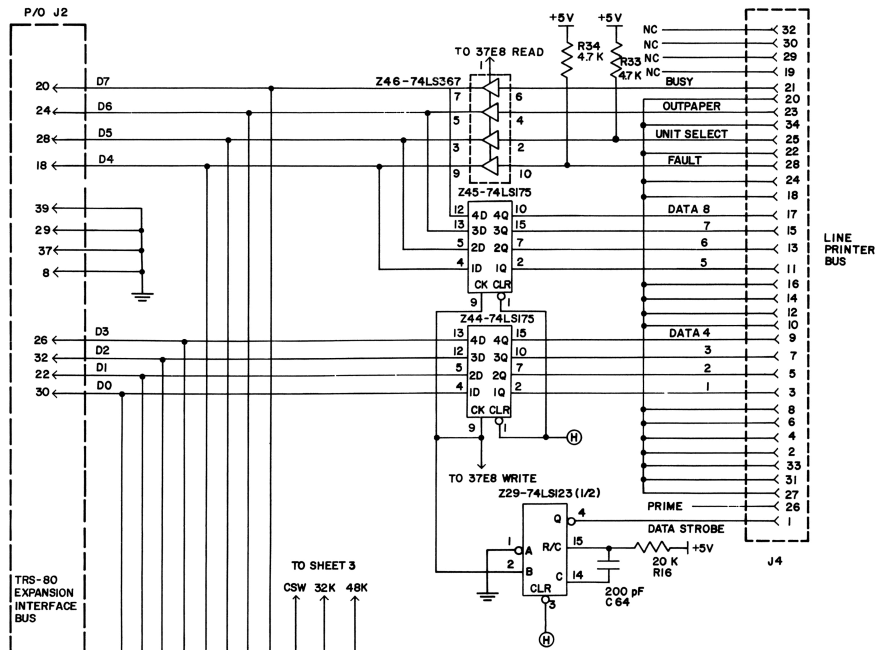

TRS-80 EXPANSION INTERFACE SERVICE MANUAL

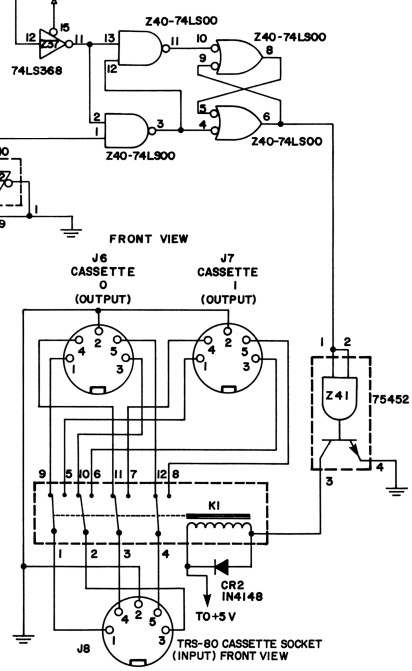
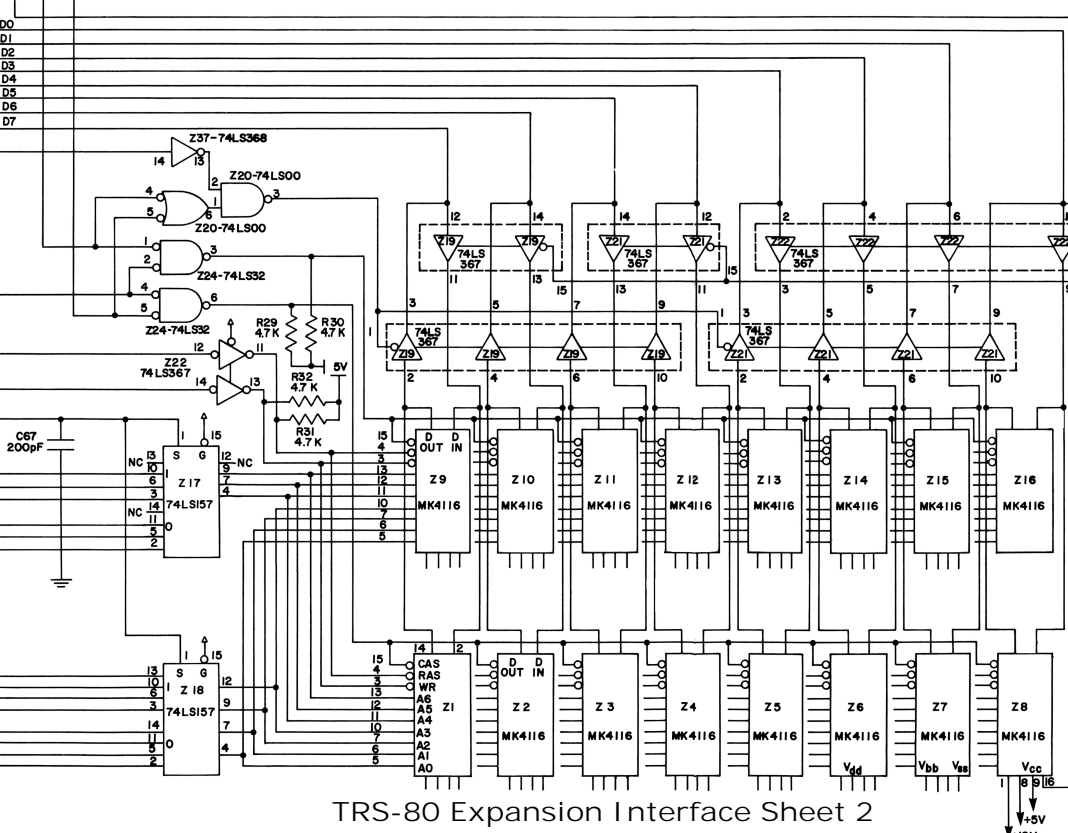
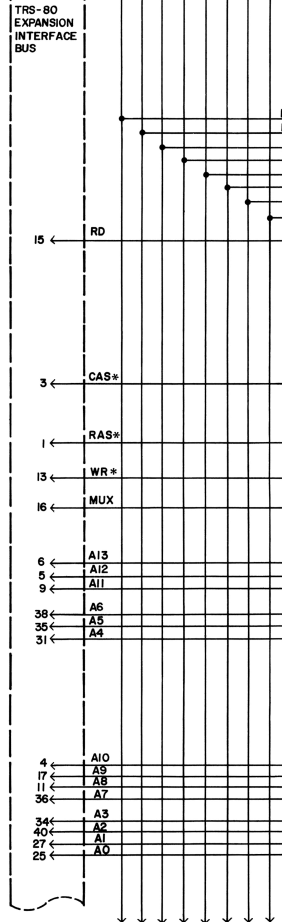

- NOTES: UNLESS OTHERWISE INDICATED:
 1.) ALL CAPACITORS ARE IN PICOFARADS, 10% .
 2.) ALL RESISTORS ARE IN OHMS, 1/4 WATT, 10% .K=1000.
 3.) ALL RAMS(MK4116) ARE IN 16 PIN SOCKETS.
 4.) PINS 1,3,4,5,6,7,8,9,10,11,12,13 AND 16 OF ALL RAMS ARE TIED IN PARALLEL.
 5.) Ⓜ DENOTES LOGICAL LEVEL 1.

TRS-80 Expansion Interface Sheet 2

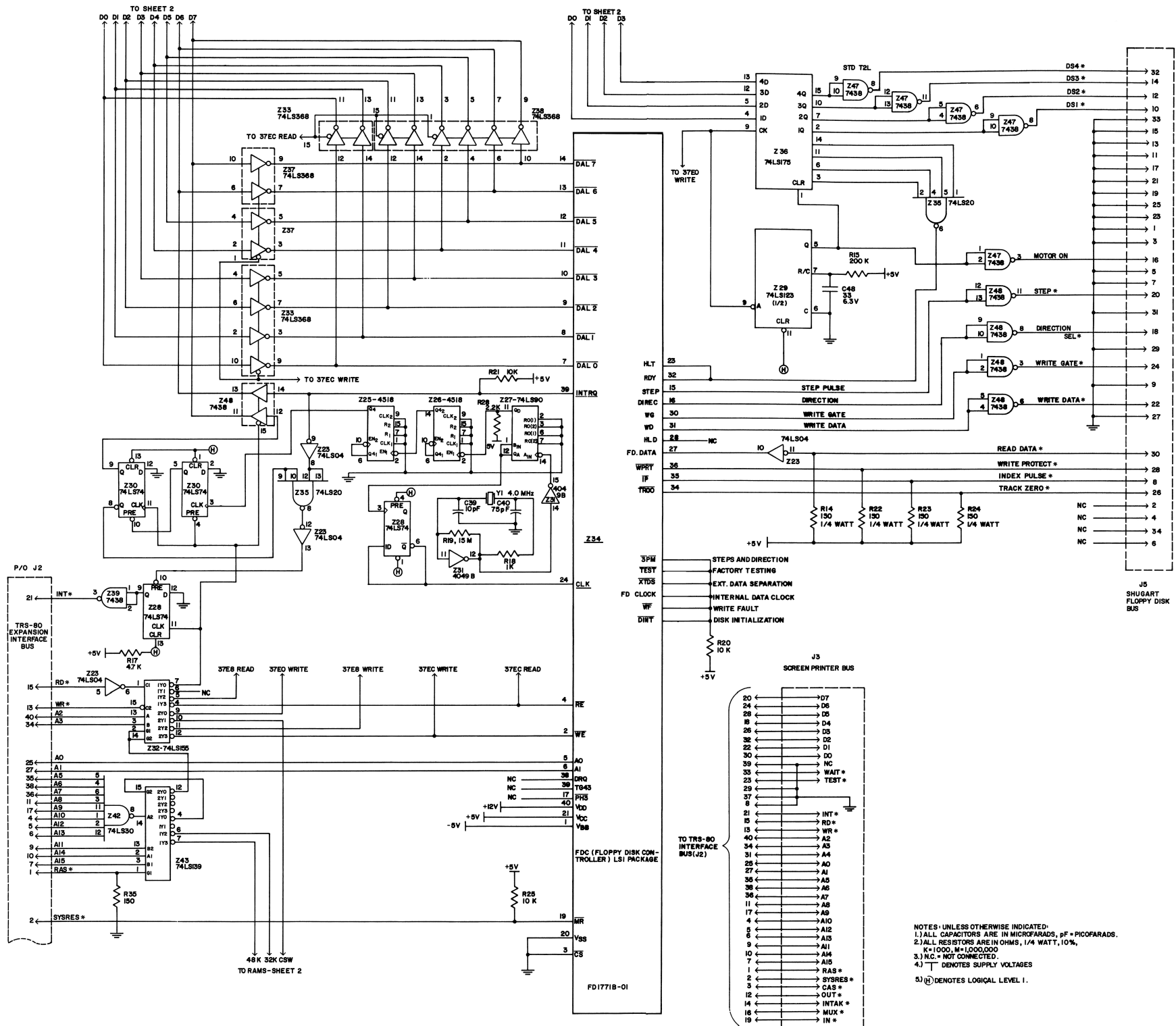

TRS-80 Expansion Interface Sheet 3