

CHAPTER 1

GENERAL INFORMATION

This document describes the Model FD1165 8-Inch Flexible Disk Drive and gives specification, installation, and interface information in sufficient detail for evaluating and planning systems.

1.1 GENERAL DESCRIPTION

The Model FD1165 Flexible Disk Drive is a compact magnetic disk storage device that uses single- or dual-sided flexible disks. With a dual-sided flexible disk and double-density format, the maximum storage capacity is 1.6 million bytes.

The disk drive is designed for a long, trouble-free service life and has a field-proven mean-time-between-failures (MTBF) of 24,000 hours.

1.2 FEATURES

The Model FD1165 Flexible Disk Drive is operated by an external controller (NEC μ PD765 is recommended) through a transistor-transistor logic (TTL) interface. Dc power is supplied and controlled externally. Operator controls on the disk drive consist of a door handle and READY and BUSY lamps on the front panel (see Figure 1-1).

1.2.1 Compact Size and Design

The most apparent features of the Model FD1165 Flexible Disk Drive are its small size and light weight. The disk drive measures 8.55 inches (217.2 mm) high, by 2.28 inches (58.0 mm) wide, by 13.20 inches (335.0 mm) deep and weighs 7.7 pounds (3.5 kg). The disk drive has all the features and performance of conventional units, and maintains media and interface compatibility with them. Because of its small size, two disk drives can be mounted in the same space as one conventional drive. If only one disk drive is mounted, the remaining space can be used to store flexible disks.

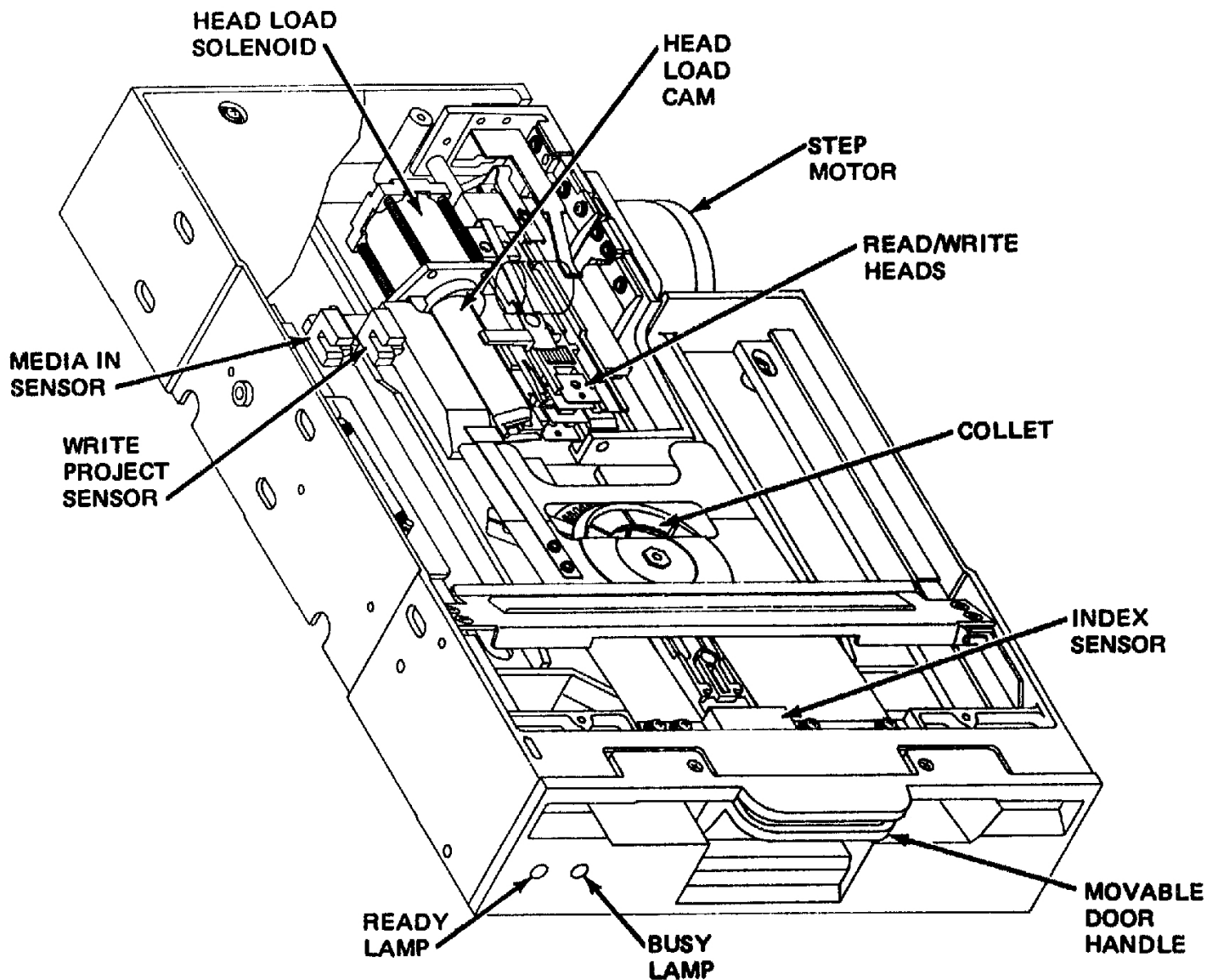

Figure 1-1 Model FD1165 Flexible Disk Drive Components

The simplified design of the disk drive improves its reliability and simplifies repair. In particular, its dc direct drive spindle motor eliminates problems associated with conventional ac motor drives.

- Drive pulleys and belts, and the problems associated with these parts are eliminated.
- The special brush type dc motor draws less power (only 26 w) than conventional ac motors, so that low power, inexpensive power supplies can be used.
- Concerns about different ac voltages and frequencies are eliminated.
- Less heat is produced by the disk drive than with conventional units.

1.2.2 Loading/Ejection, Interlocks, and Sensors

Insert a flexible disk into the disk drive and close the door. When the door handle latches closed, a collet presses into the hole of the flexible disk, centering it and clamping it in operating position on a spindle below. By the same action the drive motor receives dc power, it moves the spindle, rotating the flexible disk at 360 revolutions per minute (rpm). Sensors in the disk drive detect the following:

- a. That the flexible disk is properly inserted and the door slot is closed.
- b. Whether a single- or dual-sided flexible disk is loaded.
- c. Whether the flexible disk has a write protect notch.
- d. Whether the magnetic head is located on the 00 track of the disk.

An index sensor generates a pulse once for each rotation of the flexible disk, providing a time reference.

Before you can unload the flexible disk, the BUSY lamp on the front panel must be off. The door slot does not open if the flexible disk is being used by the host controller.

1.2.3 Dc Direct Drive Spindle Motor

The disk spindle is driven by a dc motor. This direct drive dc motor makes drive belts and pulleys unnecessary, and minimizes the power required. The motor provides a media up-to-speed time of only 600 ms.

The flexible disk is accurately centered and clamped onto the spindle by a collet. Clamp pressure is relieved by springs in both the spindle and collet to protect the flexible disk even if it is warped.

1.2.4 Read/Write Heads

Data is written onto the flexible disk and read from it using ceramic magnetic read/write heads. The read/write heads are located on each side of the flexible disk and are mounted on a precision guide-bar carriage, enabling the heads to be shifted from track to track. During loading and unloading of a flexible disk, the heads are held away from the flexible disk surface.

1.2.5 Microprocessor-Controlled Head Positioning

The head positioning (access) mechanism consists of a step motor, linked to the carriage by a tensioned steel belt. This arrangement provides fast and accurate access. The step motor is controlled by a microprocessor, increasing head positioning reliability. Each pulse command rotates the step motor shaft 1.8 degrees, which moves a head/carriage 1/2 track on the flexible disk.

1.2.6 Microprocessor-Controlled Head Loading

When the disk drive logic circuit receives a head load instruction, it lowers the heads onto the flexible disk surfaces. Head loading force is controlled by a solenoid. A microprocessor-controlled special cam governs head loading, reducing damage to the flexible disk surface, thereby increasing flexible disk operating life and data integrity.

1.2.7 Display LEDs

Two LEDs on the front panel provide a visual display of the ready and busy states of the disk drive.

1.2.8 Door Lock Solenoid

The door lock solenoid makes it impossible to remove a disk during certain drive operations, thereby preventing data loss or physical damage to the flexible disk.

1.2.9 Interface

Signal and data lines interface with the host controller is by a 50-pin edge card connector. The 21 active lines (plus grounds) are all operated at TTL levels. The Variable Frequency Oscillator (VFO) option requires another three lines.

1.2.10 Diagnostics

The disk drive diagnostics consist of movable printed circuit board (PCB) plugs that can be used to establish test conditions.

1.2.11 Option Selection

The FD1165 is equipped with signal function selection plugs, as well as drive door and busy lamp function plugs. These function plugs allow you to tailor the disk drive to suit your particular needs. See Section 2.4.2.3 for a full description of these features.

1.2.12 Variable Frequency Oscillator (Optional)

The optional VFO makes the interface signals to the controller more stable. This feature increases the overall reliability of the disk drive.

1.3 SPECIFICATIONS

Capacities for the Model FD1165 Flexible Disk Drive are listed in Table 1-1. Mechanical, electrical, environmental, and performance specifications are listed in Table 1-2.

Table 1-1 Model FD1165 Capacity (Formatted)

CAPACITY (Bytes)	SINGLE-SIDED SINGLE-DENSITY			DUAL-SIDED SINGLE-DENSITY			DUAL-SIDED DOUBLE-DENSITY		
	246K	284K	303K	493K	568K	606K	985K	1137K	1212K
Per diskette	3328	3840	4096	3328	3840	4096	6656	7680	8192
Per track	128	256	512	128	256	512	256	512	1024
Per sector									
Sectors per track	26	15	8	26	15	8	26	15	8

Table 1-2 Model FD1165 Specifications

FEATURES	SPECIFICATIONS		
	Single-Sided Single-Density	Dual-Sided Single-Density	Dual-Sided Double-Density
Capacity (unformatted)	400K bytes	800K bytes	1,600K bytes
Capacity (formatted-maximum)			
Per Disk	303K bytes	606K bytes	1,212K bytes
Per Track	4,096 bytes	4,096 bytes	8,192 bytes
Per Sector	512 bytes	512 bytes	1,024 bytes
Tracks per Disk	77	154	154
Bit Density	3,268 bpi	3,408 bpi	6,816 bpi
Transfer Rate	250K bps	250K bps	500K bps
Recording Method	FM	FM	FMM

Table 1-2 Model FD1165 Specifications (cont'd)

FEATURES	SPECIFICATIONS
Number of Sectors/Track Track Density Rotational Speed Access Time Track-to-Track Seek settling time Head load time Latency time (average) Start time	8 48 tpi 360 rpm 3.0 ms 15.0 ms 30.0 ms 83.3 ms 0.6 second
Power requirement Power consumption Mechanical Height Width Depth Weight Environmental Ambient temperature Operating: Non-operating: Relative humidity Operating: Reliability Mean Time Between Failures Mean Time To Repair Component Life Soft Error Rates Hard Error Rates Seek Error Rates Media IBM Diskette 1 or equivalent IBM Diskette 2 or equivalent IBM Diskette 2D or equivalent	+24 Vdc $\pm 10\%$ @ 0.9 Amp (maximum) + 5 Vdc $\pm 5\%$ @ 0.8 Amp (maximum) without VFO/ 0.9 Amp (maximum) with VFO 26 watts (27 watts with VFO) 2.28 inches (58 mm) 8.55 inches (217.2 mm) 13.19 inches (335 mm) 7.7 pounds (3.5 Kg) 50°F to +113°F (+10°C to +45°C) +23°F to +158°F (-5°C to +70°C) 20% to 80% 24,000 Power On Hours (POH) 0.5 hours 15,000 POH or 5 years 1 bit in 10 ⁹ 1 bit in 10 ¹² 1 in 10 ⁶

CHAPTER 2

INSTALLATION

This chapter tells you how to inspect, unpack, and install the Model FD1165 Flexible Disk Drive.

2.1 PRELIMINARY INSPECTION

Before unpacking the Model FD1165 Flexible Disk Drive, inspect the shipping carton for any damage. If there is damage, notify the carrier immediately. Do not open the carton until the carrier's representative inspects it. If the carton is undamaged, follow the unpacking procedure.

2.2 UNPACKING/REPACKING PROCEDURE

This section describes how to unpack and repack the disk drive.

2.2.1 Unpacking Procedure

To unpack the disk drive, refer to Figure 2-1 and follow these steps. Save all shipping materials for possible future use.

- a. Remove the tape band from around the shipping package.
- b. Slide the styrofoam case out of the cardboard surround.
- c. Open the styrofoam case.
- d. Remove the plastic film cover from the disk drive.
- e. Inspect the disk drive for any shipment damage.

2.2.2 Repacking Procedure

To repackage a disk drive for reshipment, reverse the procedure in Section 2.2.1.

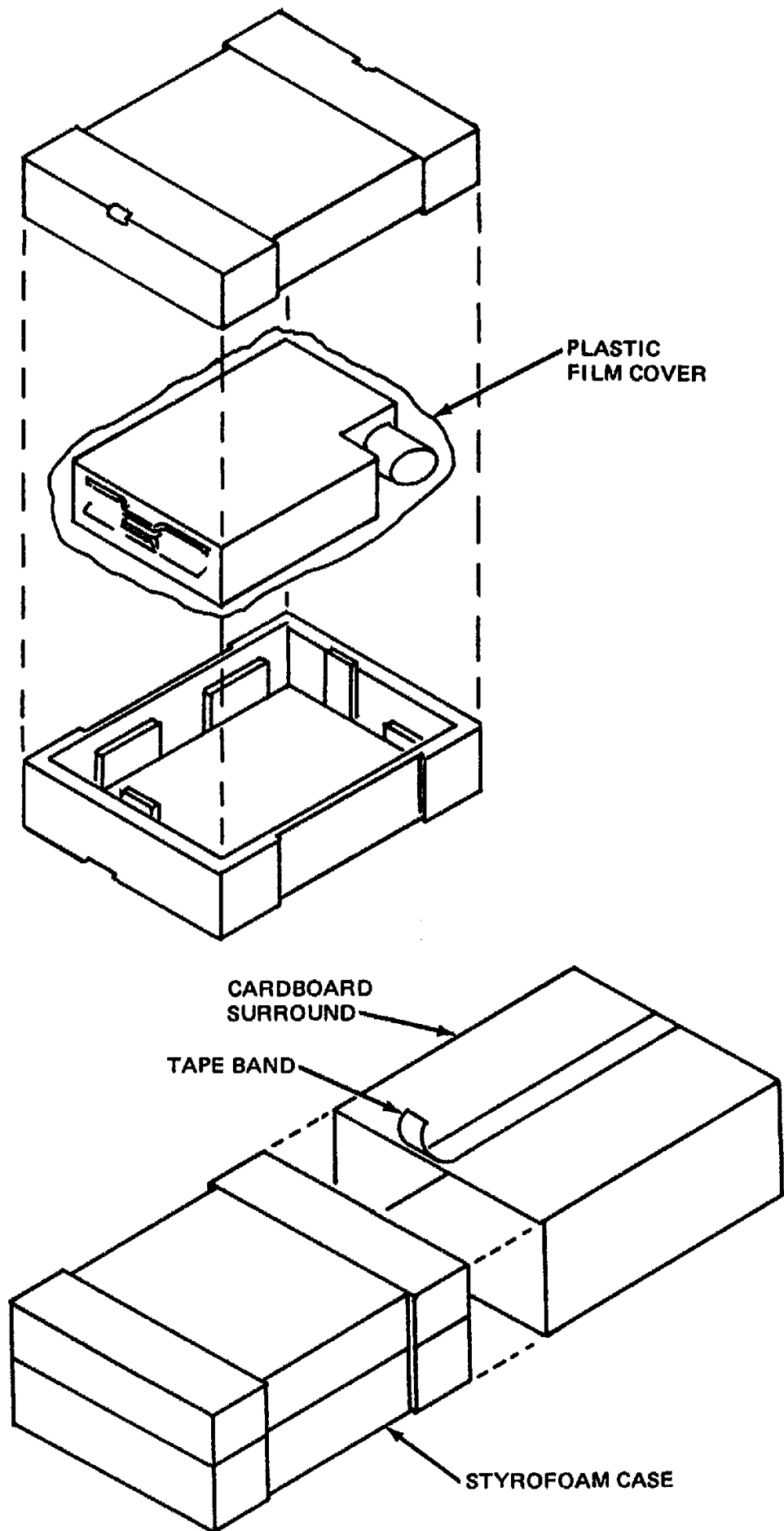

Figure 2-1 Unpacking Diagram

2.3 SYSTEM REQUIREMENTS

This section describes the environmental, space and weight, and power requirements.

2.3.1 Operating Environment

Install the disk drive in any clean, relatively dust-free environment with an ambient temperature of 50°F to 113°F (10°C to 45°C) and relative humidity of 20% to 80%. The maximum ambient stray magnetic field is specified as 4000 A/m. Typical heat dissipation by the disk drive is 22.3 Kcal/h (23.3 Kcal/h with VFO).

2.3.2 Space and Weight Data

The disk drive is designed for vertical, horizontal, or perpendicular shelf mounting. Provide space for cabling and servicing. Refer to Figure 2-2 for overall dimensions. The unit weighs 7.7 pounds (3.5 Kg).

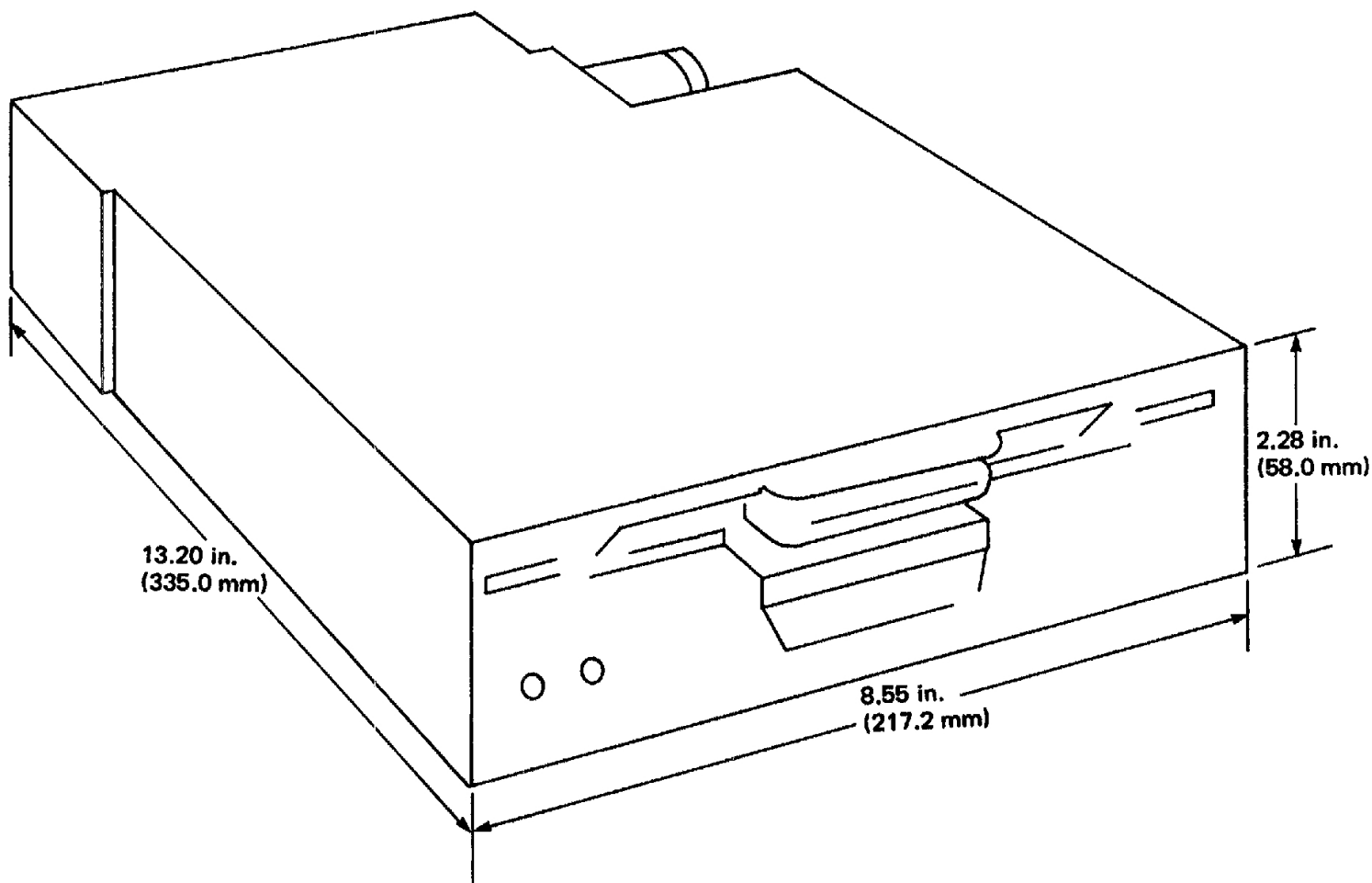

Figure 2-2 Disk Drive Dimensions

2.3.3 Power Requirements

Because the disk drive does not include a power supply, a dc source must be supplied as follows.

SPECIFICATION	+24 V POWER SUPPLY	+5 V POWER SUPPLY
Voltage	+24 \pm 10%	+5 V \pm 5%
Normal Current	0.75 A	0.8 A (Without VFO) 0.9 A (With VFO)
Starting Current	0.9 A	0.8 A (Without VFO) 0.9 A (With VFO)
Ripple voltage	Not greater than 400 mVpp	Not greater than 70 mVpp
Transient response time	200 ms	

2.4 INSTALLATION PROCEDURE

Perform the following procedures to install the disk drive.

2.4.1 Preinstallation Inspection

- a. Inspect for damage, loose parts, or other obvious indications of problems. Check that all connectors are tightly mated.
- b. Remove the dummy flexible disk from the unit.
- c. Insert a flexible disk through the door, press the door handle to latch position, and check that the collet assembly engages the flexible disk without binding. Turn the spindle and check that the flexible disk rotates freely.
- d. Press the door handle and check that the flexible disk is ejected.

2.4.2 Drive Designation

If more than one disk drive is connected to the same controller and the signal interface connectors are wired in series from a common controller port (daisy chain), remove the terminating resistors from all disk drive PCBs except the last unit in the series. Instructions for this procedure are provided in Section 2.4.2.1. If more than one disk drive is connected to a single controller, identify each disk drive by an addressable number (DX1, DX2, DX3, or DX4). Instructions for this procedure are provided in Section 2.4.2.2.

2.4.2.1 Terminator Resistors

All disk drives are shipped with terminator resistor arrays (RN1 and RN2) installed as shown in Figure 2-3. Do not remove these resistors when only a single disk drive is used in a system.

Do not remove these resistors when two or more disk drives are served by a single controller but are connected in parallel as shown by (A) in Figure 2-4. However, if two or more disk drives are connected to the controller on a common line in series (daisy chain) as shown in (B) of Figure 2-4, remove RN1 and RN2 from each disk drive except the last one in the circuit.

2.4.2.2 Drive Identification Selection (DX)

When only one disk drive is used in a system, insert the DRIVE SELECTION shorting plug (see Figure 2-3) to identify that drive as DX1. When two or more disk drives are used in a system (four maximum), assign each one a different DX number and insert the shorting plug for that unit appropriately (see Figure 2-3). The unit is supplied with DX1 selected.

2.4.2.3 Option Selection

The following section describes option selection on the FD1165 PCB. See Figure 2-3 for the location of the selection plugs and pins and a configuration chart. See Chapter 3 for an explanation of the signals.

HEAD LOAD PLUG (HL)

When you select plug position 1, head load action is initiated by a Head Load signal from the controller. When you select plug position 2, head load action is initiated by a Drive Select signal from the controller. The unit is supplied with HL 1 selected.

RADIAL READY PLUG (RX)

When you select plug position 1, the Ready signal sent from the disk drive is gated by the Drive Select signal. When you select plug position 2, the Ready signal is independent of the drive select signal. The unit is supplied with RX 1 selected.

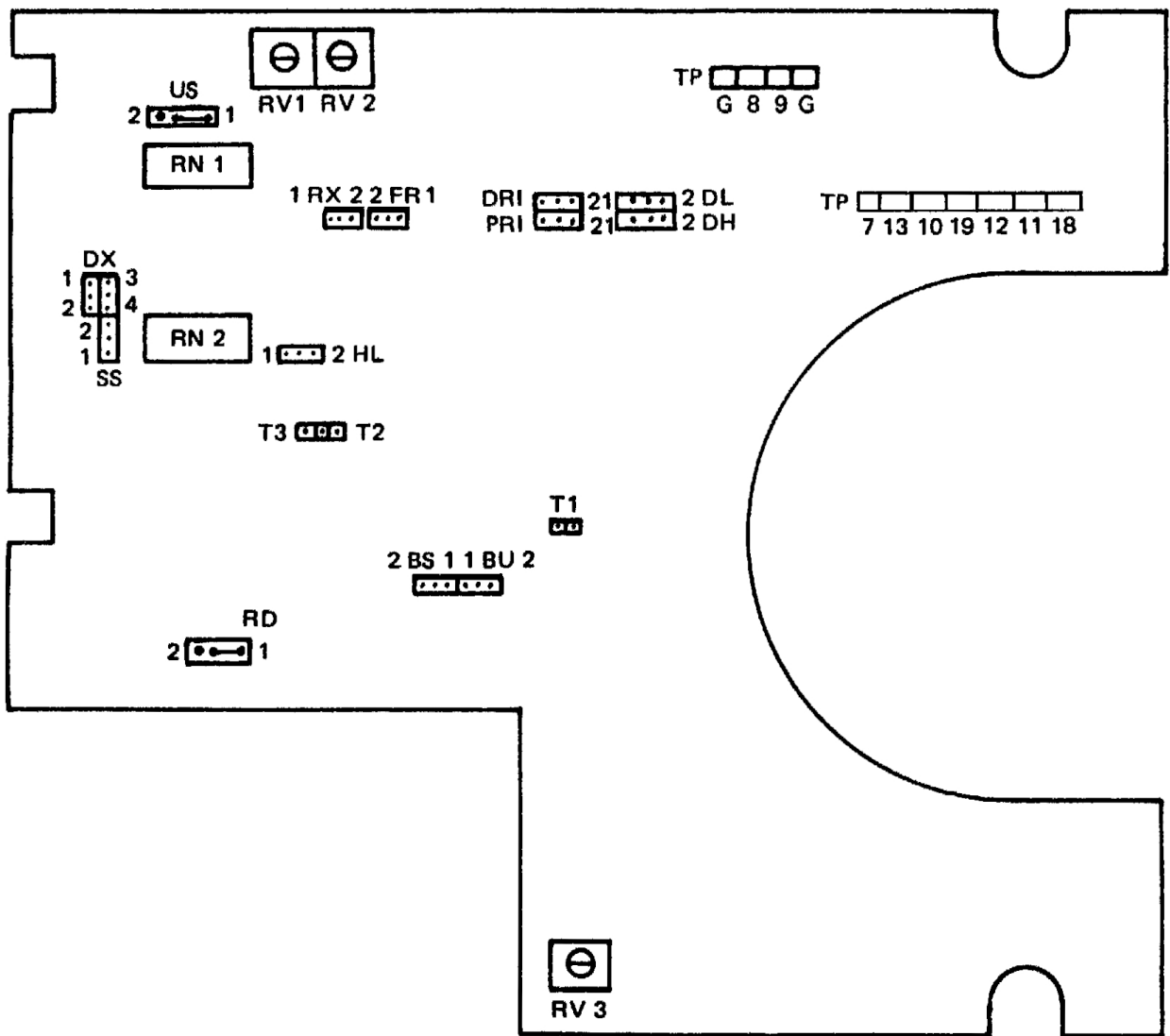

	DX1	DX2	DX3	DX4
DX PLUG	1 3	1 3	1 3	1 3
	2 4	2 4	2 4	2 4

RX,HL,DR, PR, DL, DH, BU, PLUGS	POS1	POS2

BS,FR, PLUGS	POS1	POS2

US,RD, PINS (SOLDER TYPE)	POS1	POS2

T2,T3	T2	T3
PLUGS		

Figure 2-3 Terminator Resistor and Selection Plug Location and Selection Plug Configuration on PCB

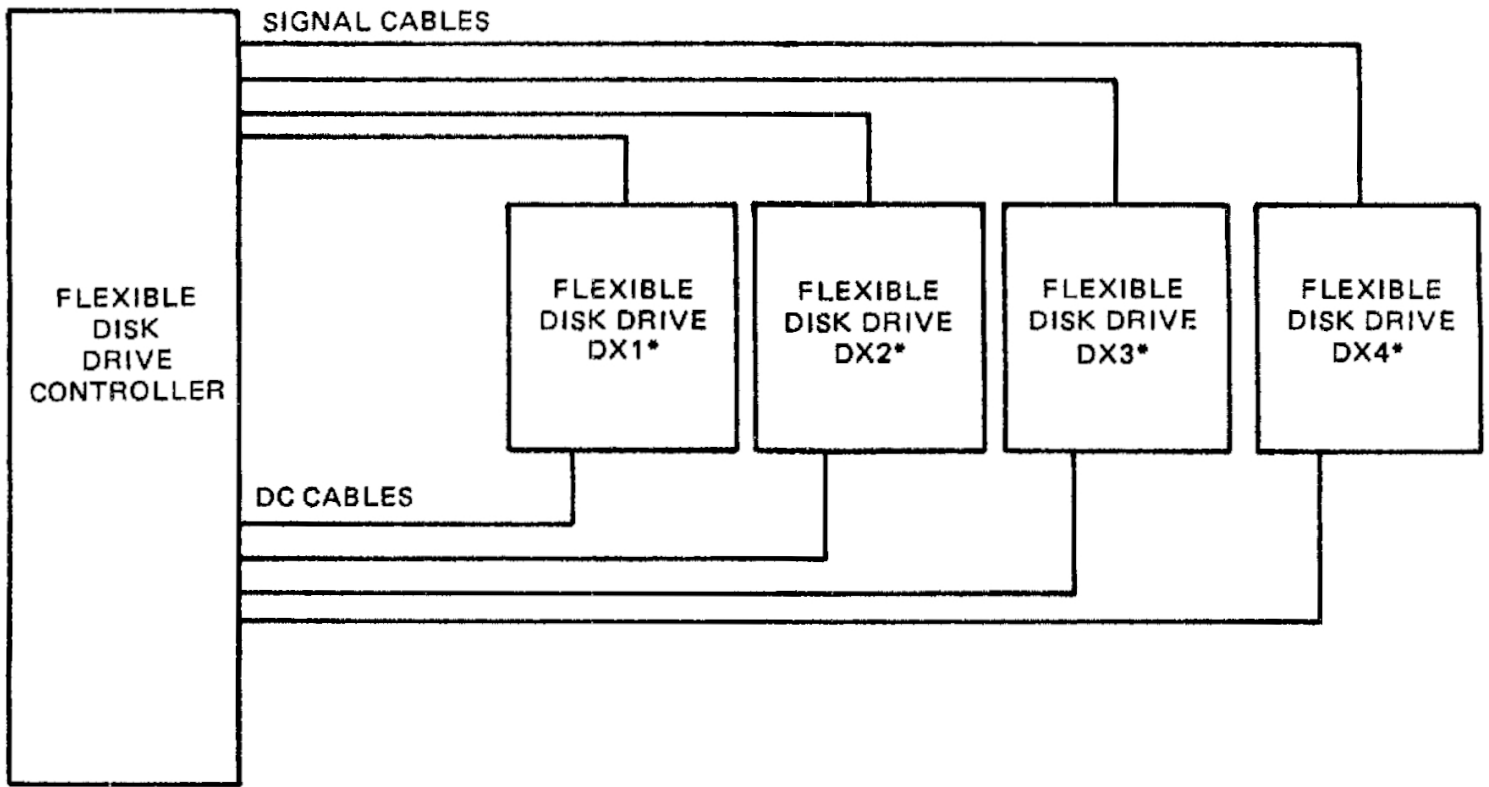

(A) PARALLEL CONFIGURATION

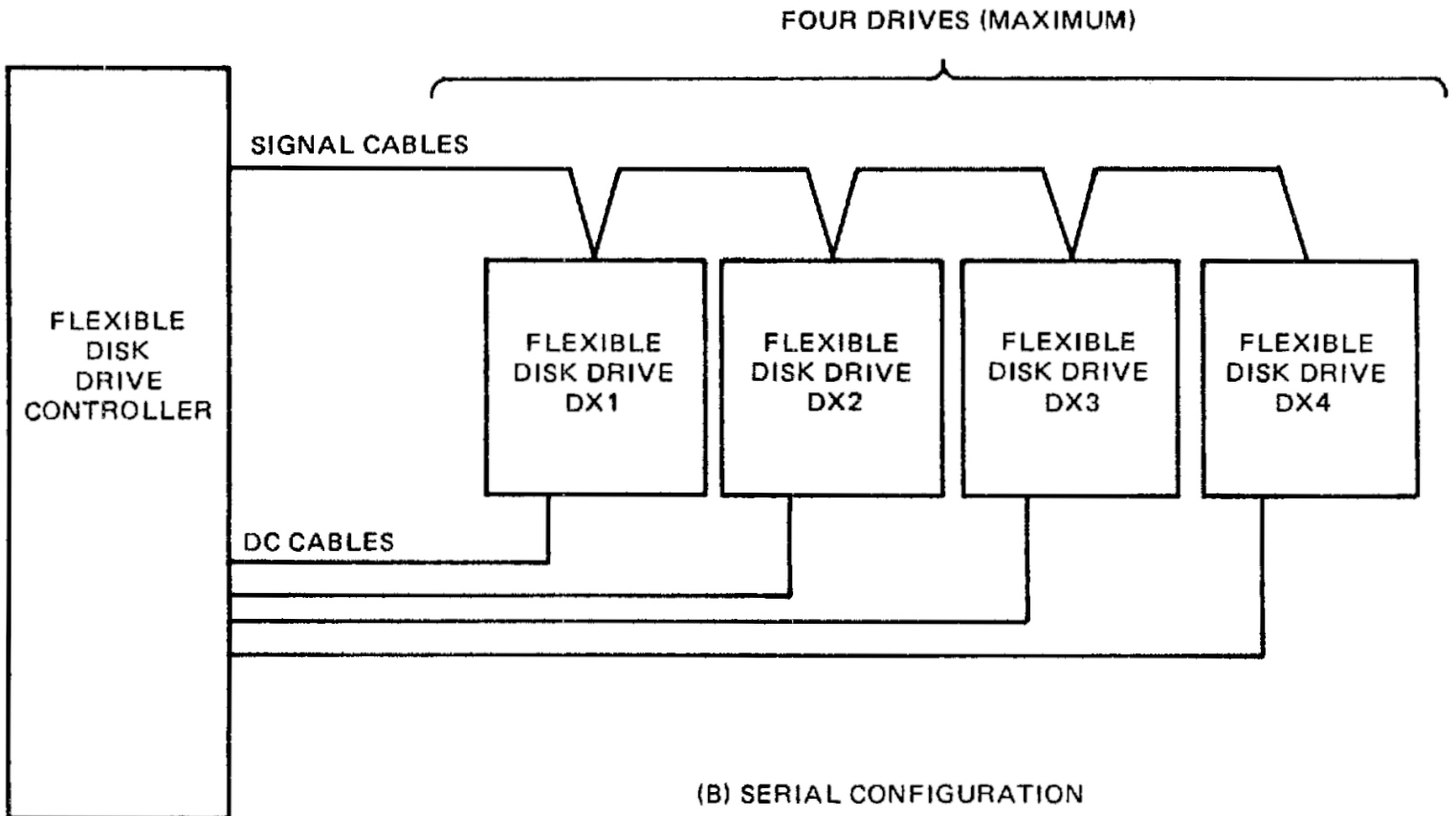

(B) SERIAL CONFIGURATION

*MOUNT TERMINATOR RESISTOR ARRAYS RN1 AND RN2

Figure 2-4 Cable Connections from Disk Drives to Controller

SIDE SELECT PLUG (SS)

When you select plug position 1, the Side Select signal from the controller determines disk side. When you select plug position 2, the Direction Signal from the controller determines disk side. If the Direction Signal level is high, the unit selects side 0. If the Direction Signal level is low, the unit selects side 2. The unit is supplied with SS 1 selected.

WRITE PROTECT PLUG (PR)

When you select plug position 1, the disk drive sends a Write Protect signal to the controller and prevents recording if the flexible disk has a write protect notch. When you select plug position 2, the disk drive sends a Write Protect signal to the controller but allows recording, even if the flexible disk has a write protect notch. The unit is supplied with PR 1 selected.

FILE UNSAFE PLUG (FR)

When you select plug position 1, you disable the File Unsafe function. When you select plug position 2, you enable the File Unsafe function. The unit is supplied with FR 2 selected.

DOOR LOCK PLUGS (DR, DL, DH)

The FD1165 three door lock function plugs, which you use in different combinations, determine when a door lock condition occurs (see Table 2-1). The flexible disk cannot be removed from the disk drive when a door lock condition exists. The door lock condition consists of a lock function or a hold function.

- DR Plug

When you select plug position 1, the disk drive door locks when Ready status, Drive Select status, and Head Load status are present. When you select plug position 2, the door locks independently of Ready status, that is, when Drive Select status and Head Load status are present. The unit is supplied with DR 1 selected.

- DL Plug

For a door lock hold condition to occur, Drive Select and In Use signals must be present initially. The DL plug determines which signal the door lock hold status depends on. The door lock hold status will exist as long as the signal that is selected by the DL plug is present. When you select plug position 1, door lock hold depends on the Drive Select signal. When you select plug position 2, door lock hold depends on the In Use signal. The unit is supplied with DL 1 selected.

- DH Plug

This plug controls the door lock hold status. When you select plug position 1, you disable the hold status. When you select plug position 2, you enable the hold status. The unit is supplied with DH 1 selected.

Table 2-1 Door Lock Plug Combinations

NO.	PLUG ID	PLUG POSITION	IN USE PLUG POSITION	EXPLANATION
1	DR DL DH	1 1 1 (hold disable)	1	Door lock = Ready and Drive Select and Head Load or Door lock = Drive Select and In Use
2	DR DL DH	1 1 1 (hold enable)	1	Door lock = Ready and Drive Select and Head Load Door lock = Drive Select and In Use
3	DR DL DH	1 1 1	2 (disable)	Door lock = Ready and Drive Select and Head Load
4	DR DL DH	2 2 2	2	Door lock = Drive Select and Head Load

IN USE PINS (US)

You cannot select In Use by the plug method; you must solder the connections. You enable the In Use signal when you connect pin 1 to the center pin. You disable the In Use signal when you connect pin 2 to the center pin. The unit is supplied with US1 connected.

READ DATA PINS (RD)

You must solder the connections at the RD pins; you cannot select them by the plug method. You enable the Read Data signal when you connect pin 1 to the center pin. You enable the Standardized Read Data signal (for VFO option) when you connect pin 2 to the center pin. The unit is supplied with RD1 connected.

BUSY LAMP PLUGS (BU, BS)

The busy lamp plugs determine the conditions under which the busy lamp will be on. The unit is supplied with BU 2 and BS 2 selected.

- Busy Lamp on During Head Load

To have the busy lamp on when a Head Load signal is present, select BU 2 and BS 2.

- Busy Lamp on During Drive Select

To have the busy lamp on when a Drive Select signal is present, select BU 2 and BS 1.

- Busy Lamp on During In Use

To have the busy lamp on when an In Use signal is present, Select BU 1 and remove the BS plug.

2.4.2.4 Diagnostic Plugs (T2, T3)

Diagnostic tests are performed by use of the diagnostic pins T2 and T3. Normally these pins are open (not connected to the center pin).

AUTO TAP TEST

The auto tap test consists of a head load/unload action. To select the auto tap test:

- a. Turn off the power.
- b. Connect diagnostic pins T2 to the center pin.

- c. Select HL2 and connect HL2 to ground.
- d. Turn on the power and the auto tap test starts.

AUTO SEEK TEST

The auto seek test consists of a seek action from track 0 to track 76 with the read/write heads unloaded. To select the auto seek test:

- a. Turn off the power.
- b. Connect diagnostic pin T3 to the center pin.
- c. Turn on the power and the auto seek test starts.

AUTO SEEK AND TAP TEST

This test performs both auto seek and auto tap functions. To select the auto seek and tap test:

- a. Turn off the power.
- b. Connect diagnostic pins T2 and T3 to the center pin.
- c. Select HL2 and connect HL2 to ground.
- d. Turn on the power and the auto seek and tap test starts.

HEAD UNLOAD DELAY (T1)

To delay the head unload action 250 ms, short pin T1 to ground. With T1 shorted, head load/unload commands are ignored when they occur less than 250 ms apart. Normally this pin is open.

2.4.2.5 Test Pins (TP)

The TP numbers and the signals available are listed in Table 2-2. Test pins not listed in the table are used in manufacturing only.

Table 2-2 Test Pins and Signals

PIN NUMBER	SIGNAL
TP 7	Index signal for dual-sided media
TP8, 9	Analog signal (differential) of head output. Use to check or adjust CE, Azimuth, or Index burst.
TP 10	Index signal for Single-sided media
TP 11	Write Protect signal
TP 12	Track 0 signal
TP 13	Media detect sensor output

2.4.2.6 Trimpots

There are three trimpots on the PCB. RV1 and RV2 determine the write current. These trimpots are adjusted at the factory and should never be adjusted in the field. RV3 determines the speed of the spindle motor. This trimpot is adjusted at 166.6 ± 0.5 ms.

2.4.3 Mounting and Wiring

The disk drive can be mounted vertically or horizontally and perpendicular. Recommended mounting methods are shown in Figures 2-5, 2-6, and 2-7. Recommended space requirements for adequate air flow are shown in Figure 2-8. When the disk drive is installed in the standard manner, no forced air cooling is necessary. If smooth air flow cannot be ensured, you may need a forced air cooling system.

Interface cabling details are shown in Figures 2-9 and 2-10. For further details on logic lines in the connector, refer to Chapter 3.

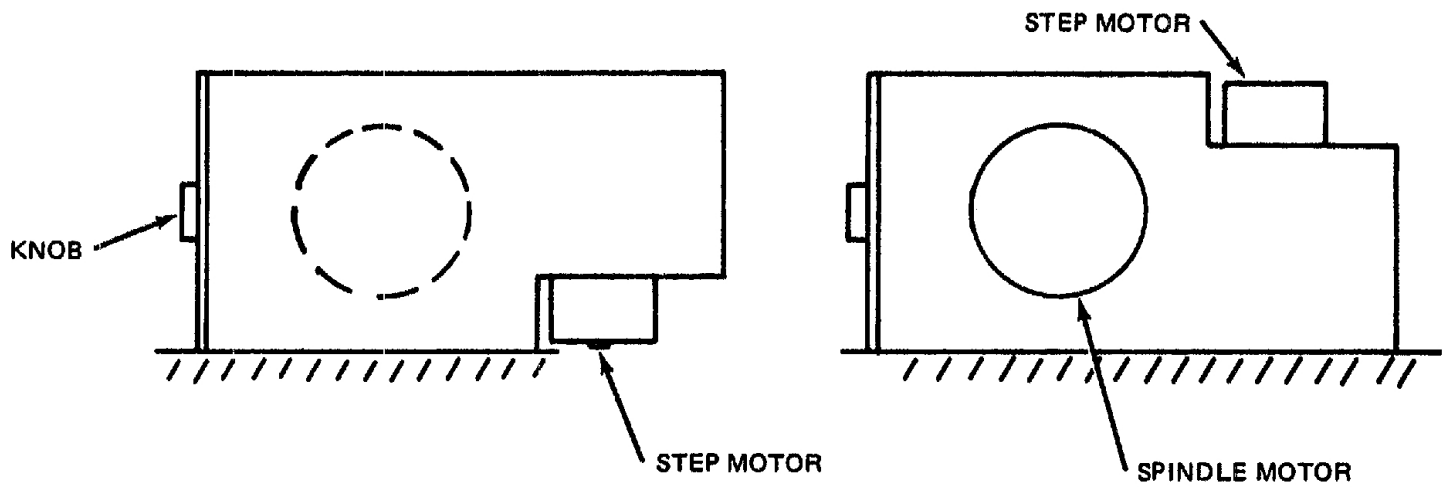

Figure 2-5 Vertical Installation

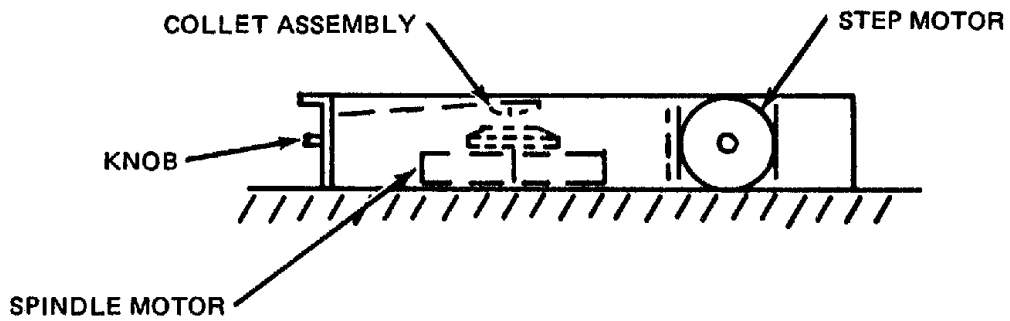

Figure 2-6 Horizontal Installation

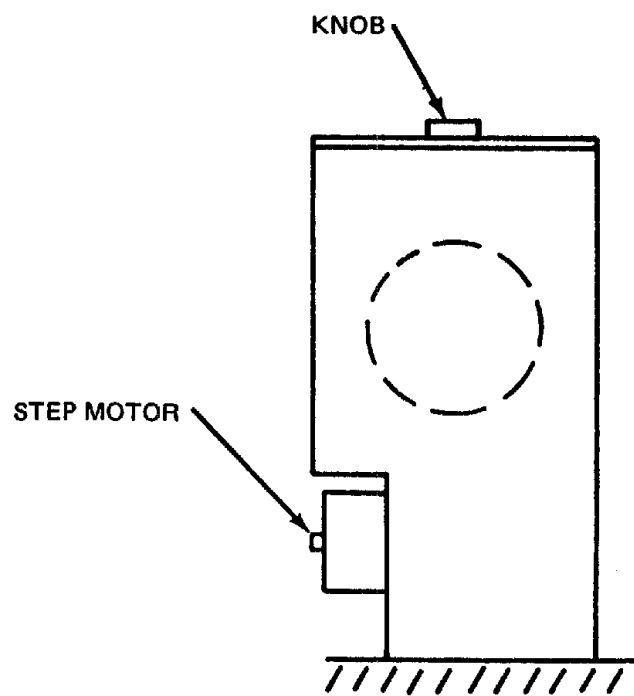
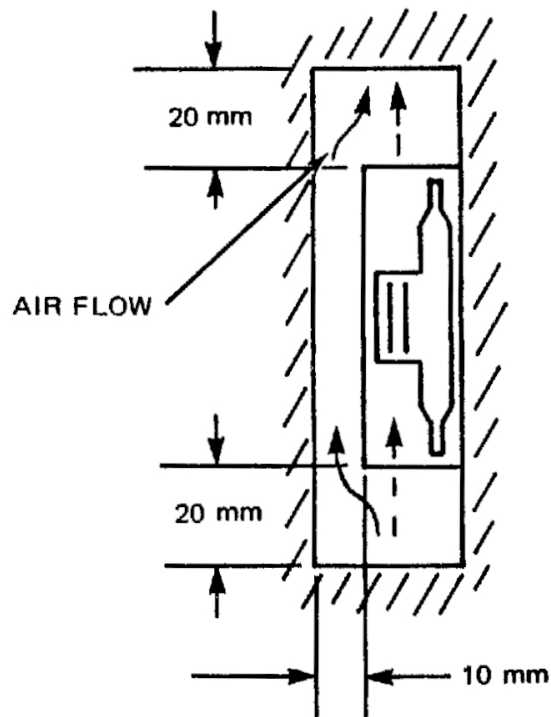
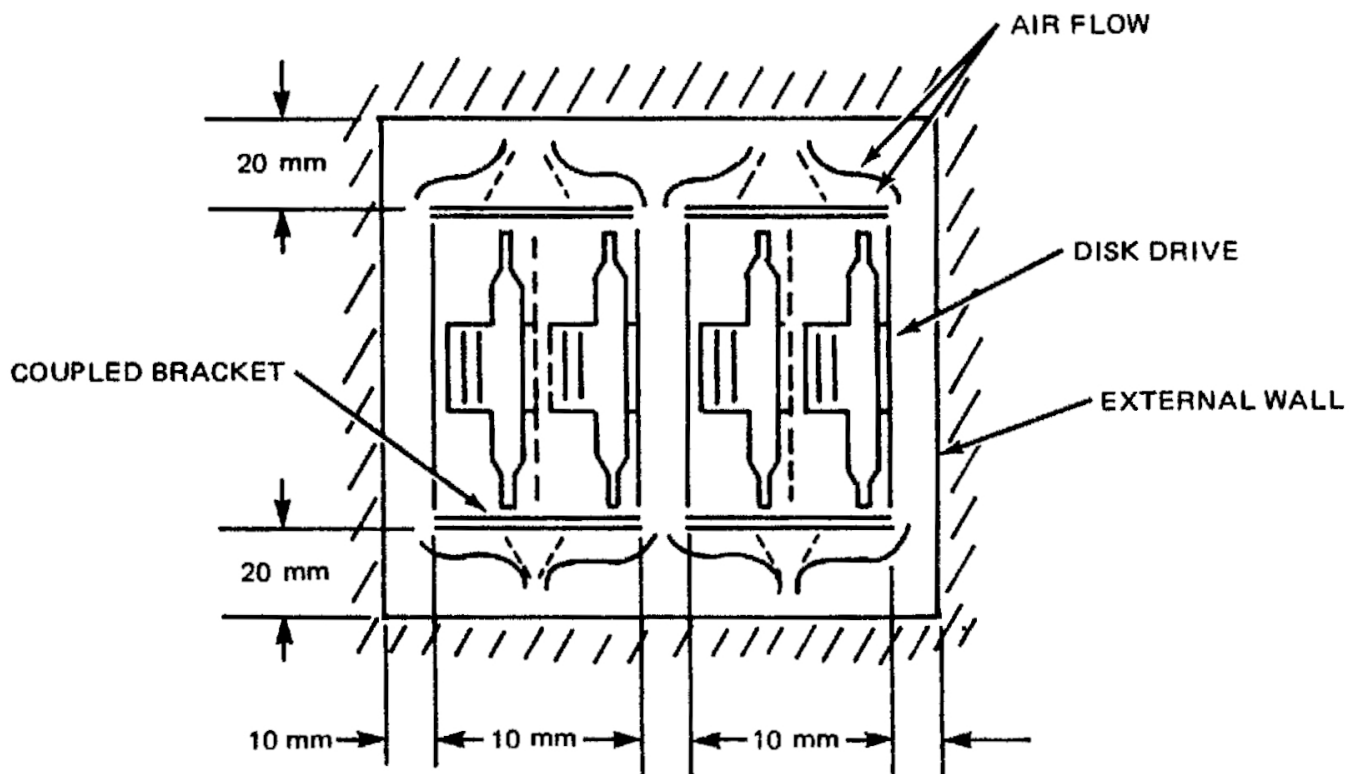

Figure 2-7 Perpendicular Installation



(A) One Disk Drive



(B) Two or Four Disk Drives

NOTE: AIR FLOW SHOWN BY SOLID LINES PASSES AROUND DISK DRIVES.
 AIR FLOW SHOWN BY BROKEN LINES PASSES THROUGH DISK DRIVES
 BY HOLES IN THE COUPLED BRACKET.

Figure 2-8 Air Flow Requirements for Natural Air Cooling

CONTROLLER	SIGNAL NAME	PIN NO.	DISK DRIVE
	LOW CURRENT	2	SIGNAL CONN.
	UNSAFE RESET	4	
	FILE UNSAFE	6	
		8	
	TWO SIDED	10	
	DISK CHANGE	12	
	SIDE SELECT	14	
	IN USE	16	
	HEAD LOAD	18	
	INDEX	20	
	READY	22	
	VFO SYNC*	24	
	DRIVE SELECT 1	26	
	DRIVE SELECT 2	28	
	DRIVE SELECT 3	30	
	DRIVE SELECT 4	32	
	DIRECTION SELECT	34	
	STEP	36	
	WRITE DATA	38	
	WRITE GATE	40	
TRACK 00	42		
WRITE PROTECT	44		
READ DATA	46		
MFM*	48		
WINDOW*	50		
		PIN NO.	
	SIGNAL NAME		POWER CONN.
	DC +24 V	1	
	GROUND	2	
	DC +5 V	3	
	GROUND	4	
		5	
		6	
	FG	7	

*SIGNALS USED ONLY WHEN VFO OPTION IS INSTALLED.

Figure 2-9 Interface Cables Between Disk Drive and Controller

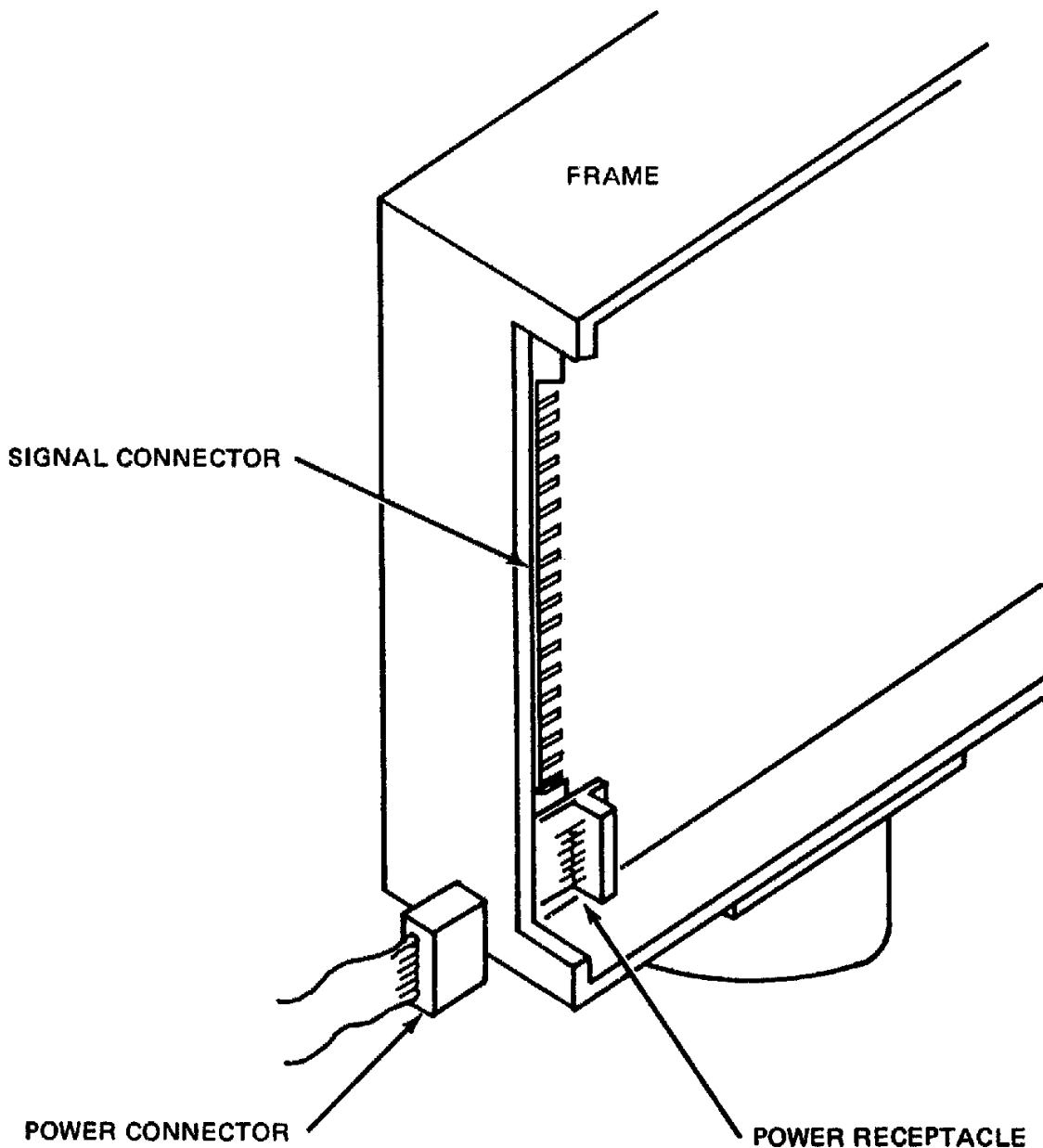

Figure 2-10 Interface Connectors Physical Location Diagram

2.4.4 Power On Testing

After you mount the disk drive and select the wiring, verify all connections, then test using this general procedure.

- a. Install a test flexible disk and apply dc power. Check for abnormalities and note that the drive motor starts and brings the disk spindle up to speed.
- b. Use whatever diagnostic test programs are available to exercise the disk drive through write and read operations, and repeated head-positioning scans.

CHAPTER 3

INTERFACE INFORMATION

This chapter describes the data and control interface lines between the FD1165 Flexible Disk Drive and its controller.

3.1 DATA INTERFACE CONNECTOR DATA

The data and control line interface connects through a 50-contact edge card connector located on the PCB of the disk drive. The pins are numbered 1 through 50. The even-numbered contacts are located on the component side of the PCB, and the odd-numbered contacts are located on the non component side of the PCB, as shown in Figure 3-1. The signal assignments for this connector are shown in Figure 3-2.

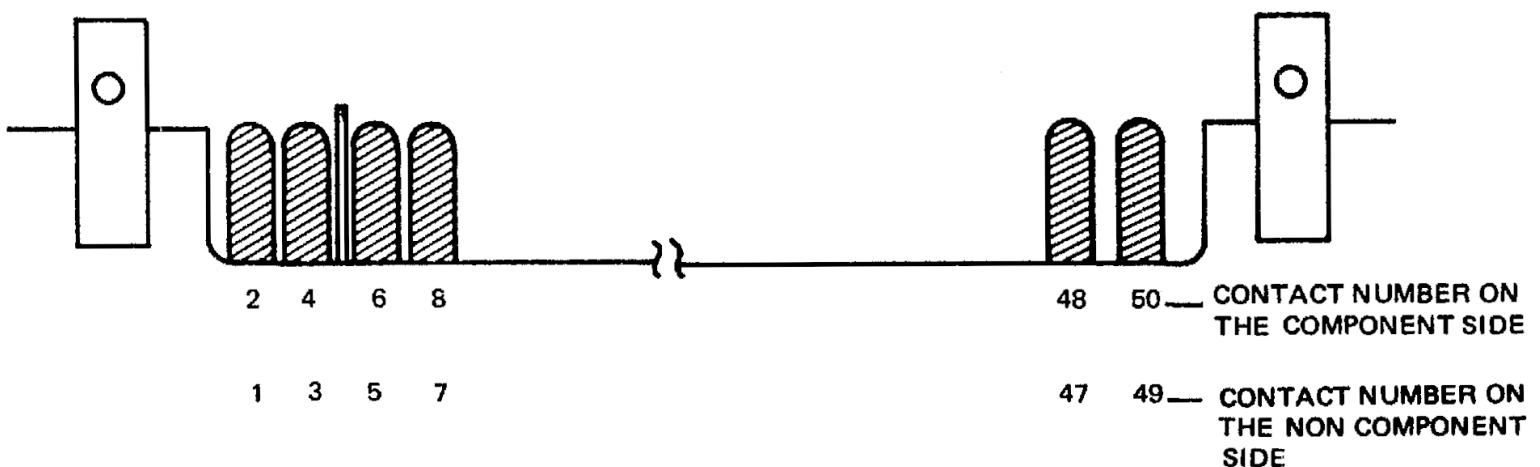

Figure 3-1 Data and Control Interface Connector

3.2 SIGNAL LEVELS

All data and control interface lines are at TTL levels, defined as follows.

LOGIC	SIGNAL LEVEL
True = Logic 0 (low level)	0 to +0.4 Vdc
False = Logic 1 (high level)	+2.5 to +5.25 Vdc

NON COMPONENT
SIDE OF PCB

COMPONENT SIDE
OF PCB

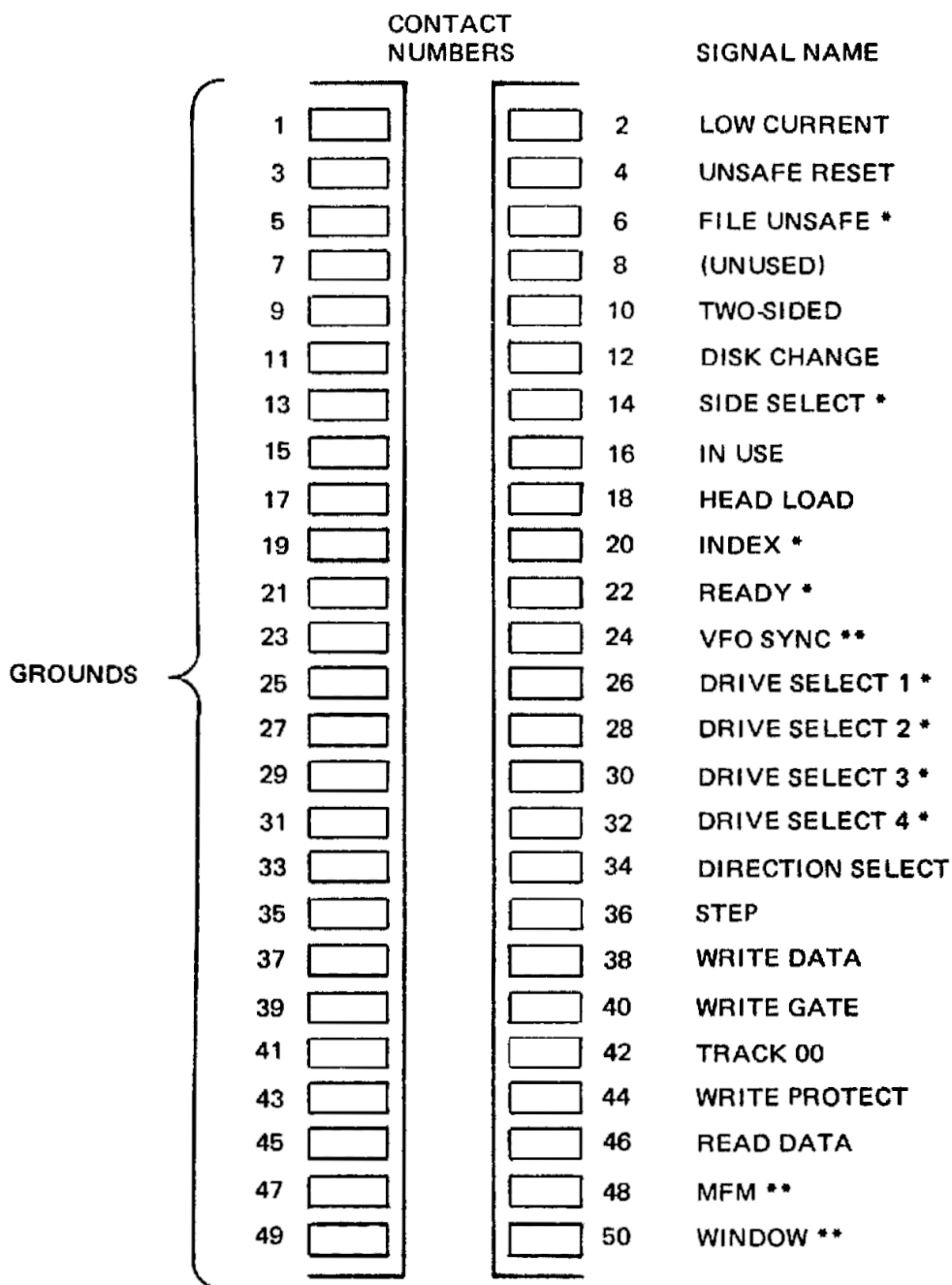

* SIGNALS ENABLED BY PLUGS

** SIGNALS USED ONLY WHEN VFO OPTION IS INSTALLED

Figure 3-2 Signal Edge Cord Connector Contact Assignments

Each driver circuit delivering a signal from the disk drive to the controller is an open collector type of SN7438, which provides a maximum sink current of 40 mA at the low level. Each receiver circuit receiving a drive signal from the controller is an LSI gate circuit, terminated at a 150-ohm resistor. Lines receiving at high speeds use a Schmitt trigger gate. The recommended driver/receiver circuits are shown in Figure 3-3.

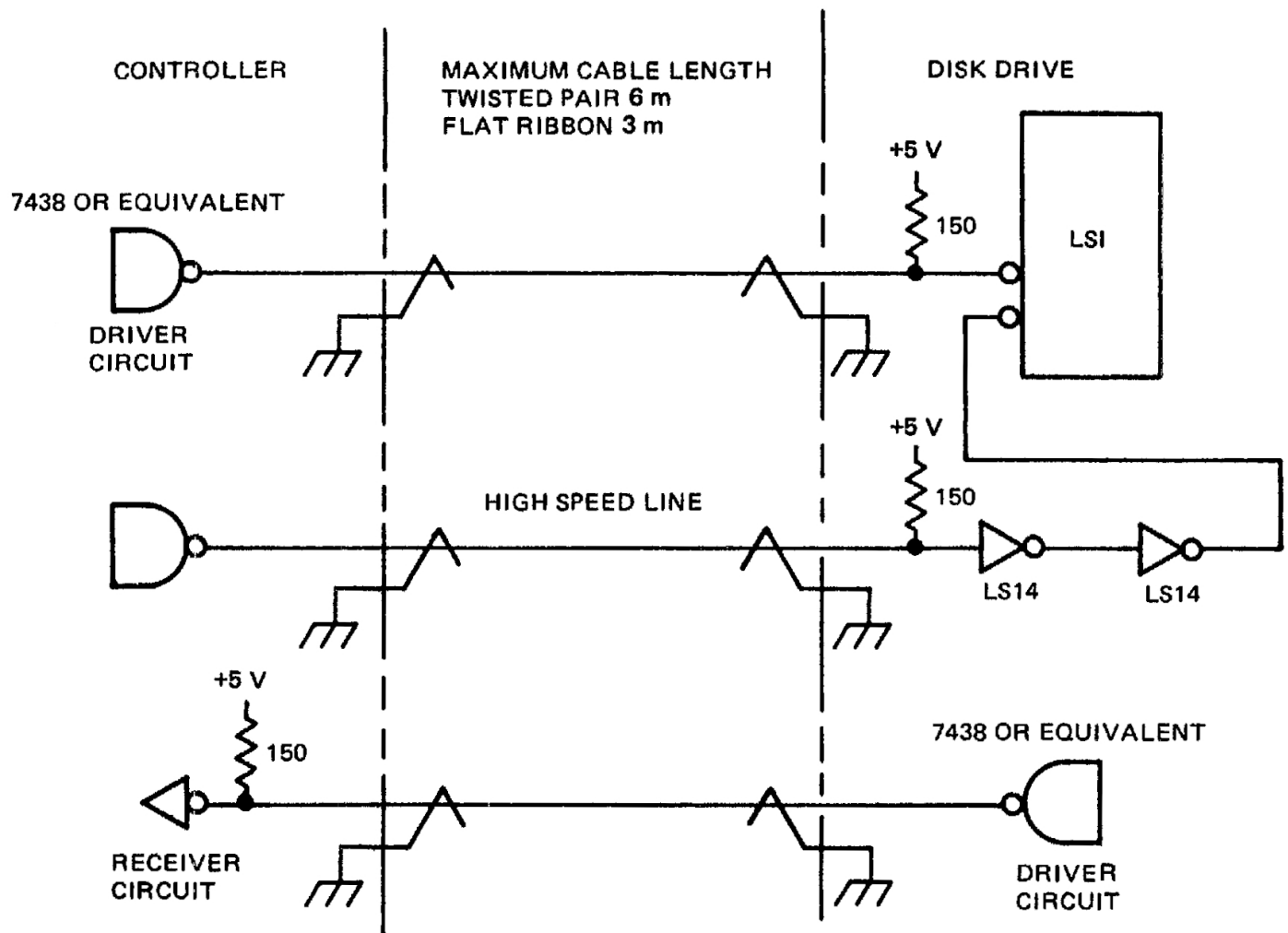

Figure 3-3 Driver and Receiver Circuits

3.3 INPUT SIGNAL FUNCTIONS

Descriptions of the disk drive input signal functions follow.

3.3.1 Drive Select 1 to 4 (DX1 to DX4)

These lines select one to four disk drives in a system. A disk drive is selected and its input/output lines are effective when its drive select line goes low.

To designate each disk drive, insert a shorting plug into the desired terminal DX1 to DX4 on the PCB. For example, to designate a specific disk drive as number 1, insert the shorting plug into the DX1 terminals (see Figure 2-3).

3.3.2 Head Load (HDL)

If the disk drive is ready, a low level on this line directs the disk drive to initiate head loading.

3.3.3 Step (STP)

This line carries a pulse that moves the heads from track to track in the direction designated by the DIRECTION SELECT line. The heads start to move at the leading (positive going) edge of each pulse. One pulse moves the heads one track. The repetition rate and width of this pulse are shown in Figure 3-4.

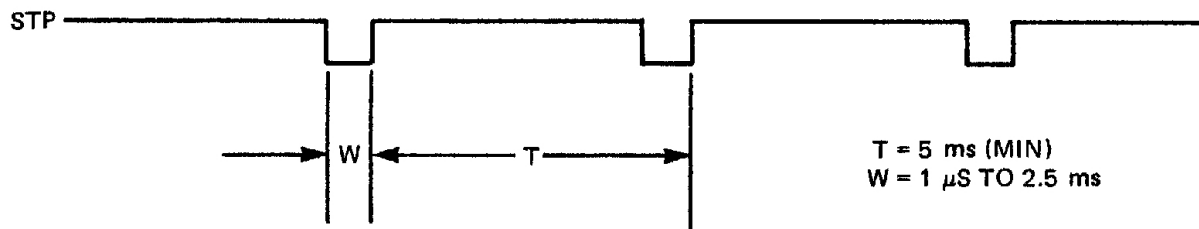

Figure 3-4 Step Signal Timing

3.3.4 Direction Select (DIR)

If DIR is at the high level, the head moves toward the external track. If it is at the low level, the head moves toward the internal track. The signal occurs 1 μs before the trailing edge of the STP signal.

3.3.5 Side Select (SSL)

If SSL is high, it selects flexible disk side 0 (upper side). If it is low, it selects side 1 (lower side). Signal SSL occurs 100 μs before the READ/WRITE operation. Note that side 0 is used in the single-sided disk.

3.3.6 Write Gate (WGT)

If this line is low, data is written to the flexible disk. If the line is high, data is read from the flexible disk.

Data is erased from the flexible disk for 560 μs after the signal level goes high. The HEAD LOAD signal can be turned off, the SIDE SELECT signal can be changed, and STEP operation can be enabled only when the WRITE GATE and ERASE signals are both at the high level. The WRITE GATE timing chart is shown in Figure 3-5.

3.3.7 Write Data (WDT)

This line (WDT) supplies the disk drive with data to be written on the flexible disk in frequency modulated (FM) or modified frequency modulated (MFM) format (see Figure 3-6).

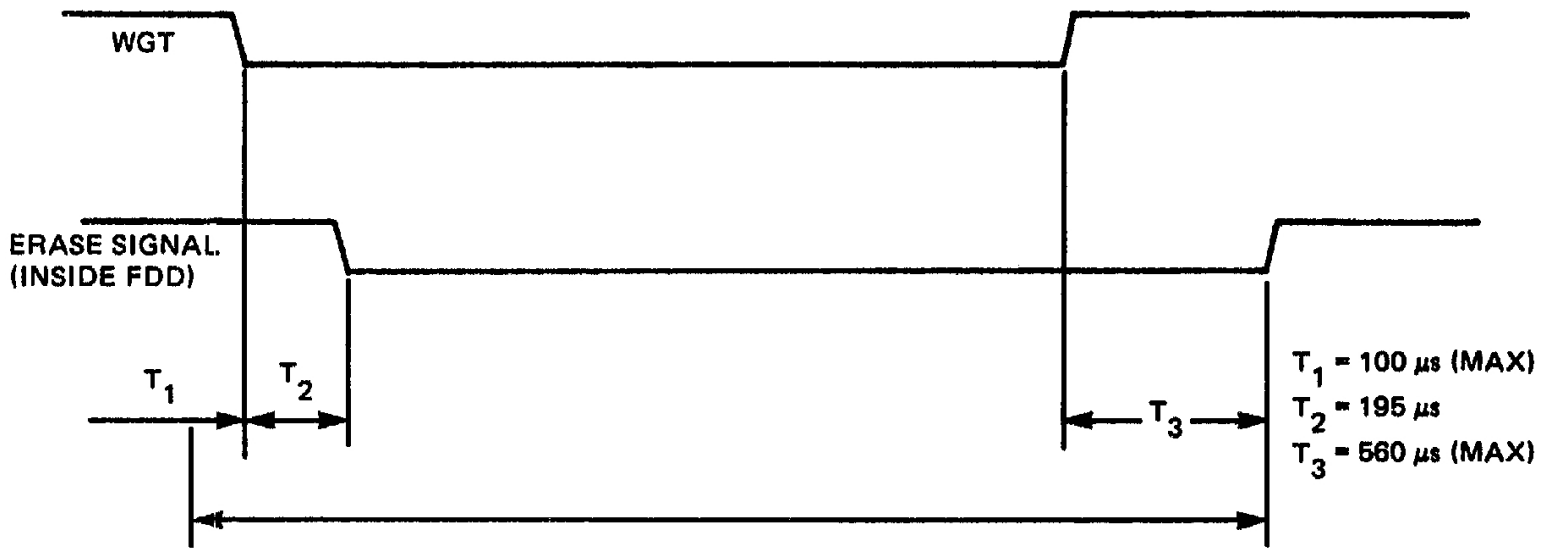

NOTE: THE HEAD LOAD SIGNAL CANNOT BE TURNED OFF, THE SIDE SELECT SIGNAL CANNOT BE CHANGED, AND THE STEP OPERATION CANNOT BE ENABLED IN THIS INTERVAL.

Figure 3-5 Write Gate Signal Timing

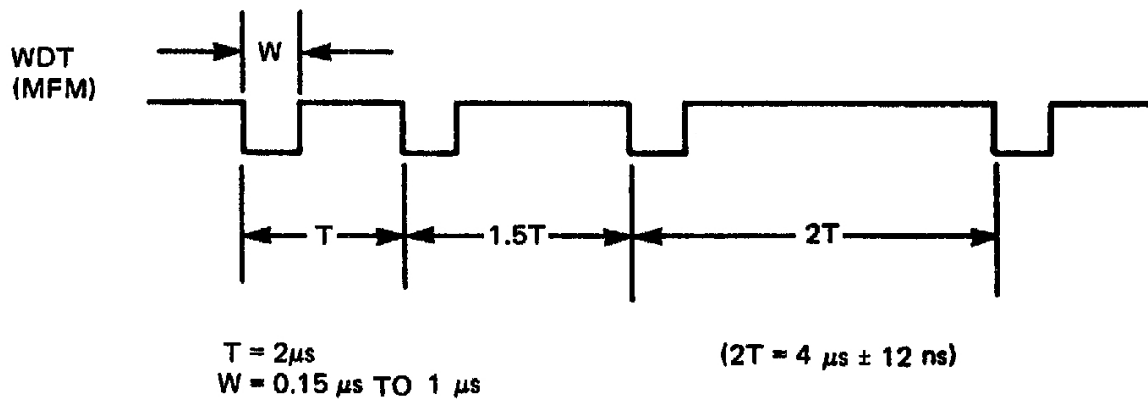
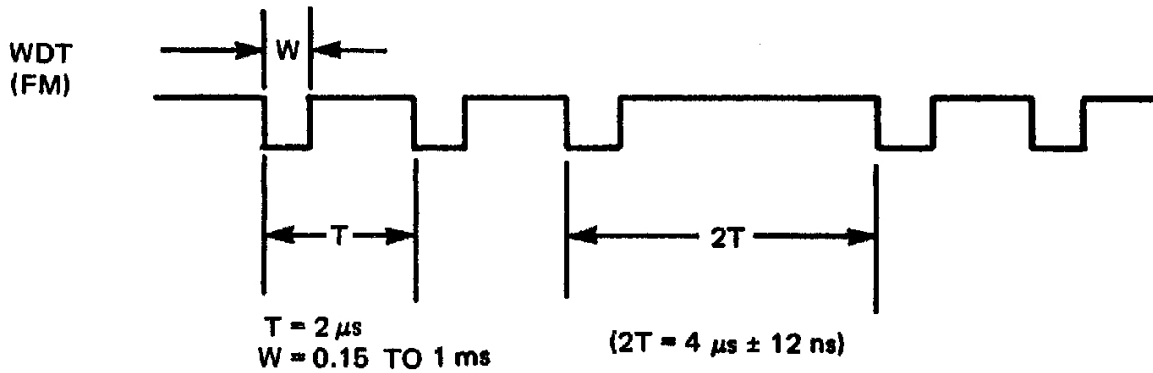

Figure 3-6 Write Data Signal Timing

3.3.8 Current Changeover (LWC)

During WRITE operations, LWC controls WRITE current to compensate for high-density records in the internal tracks. During READ operations, LWC changes the frequency characteristic of a preamplifier. For READ/WRITE operation, LWC should be high in external tracks (00 to 42) and low in internal tracks (43 to 76).

3.3.9 Reset (FLR)

A low FLR resets FILE UNSAFE status.

3.3.10 In Use

A low on this line instructs the disk drive to hold a door lock condition.

3.4 OUTPUT SIGNAL FUNCTIONS

A description of the functions of the output signals follows.

3.4.1 Index (IDX)

This line (IDX) signals the start point of a track on the flexible disk once every rotation. The resulting pulse is shown in Figure 3-7.

3.4.2 Track 00 (TKC)

When TKC is low, the head is on the zero track.

3.4.3 Dual-Sided (TSD)

This line (TSD) is high if the flexible disk is single-sided and low if it is dual-sided. If no flexible disk is inserted, TSD remains high.

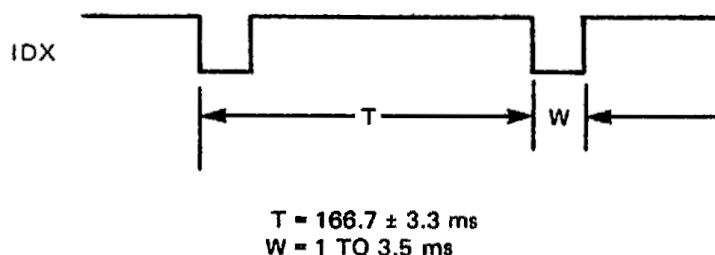

Figure 3-7 Index Signal Timing

3.4.4 Ready (RDY)

When RDY is low, the disk drive is ready, indicating the following conditions.

- Dc power is supplied.
- The flexible disk has been inserted and the door closed.
- Rotational speed of the flexible disk has reached more than 70% of speed and the disk drive logic has detected the IDX signal four or more times.
- Only side 0 has been selected if the flexible disk is single-sided.

3.4.5 File Unsafe (FUS)

A low FUS indicates an alarm condition and it inhibits write operations. This line is reset to high by the FUR signal. It is active for any of the following conditions.

- $\overline{\text{WGT.WDT}}$ - The WRITE DATA signal does not appear within 18 s after WRITE GATE becomes active.
- $\overline{\text{HDL.WGT}}$ - The WRITE GATE signal is active but HEAD LOAD is not.
- $\overline{\text{RDY.WGT}}$ - The WRITE GATE signal is active but READY is not.
- WGT.STP - The STEP signal is active at the same time the WRITE GATE signal is active.

3.4.6 Read Data (RDT)

This line (RDT) conveys signal-conditioned data read from the flexible disk drive. This line transmits the READ DATA signal or the STANDARDIZED READ DATA signal used for the VFO option (see Section 3.5.3). The READ DATA signal is transmitted only when the RD shorting plug (See Figure 2-3) is inserted on the 1 side. A typical RDT conditioned digital wavetrain is shown in Figure 3-8.

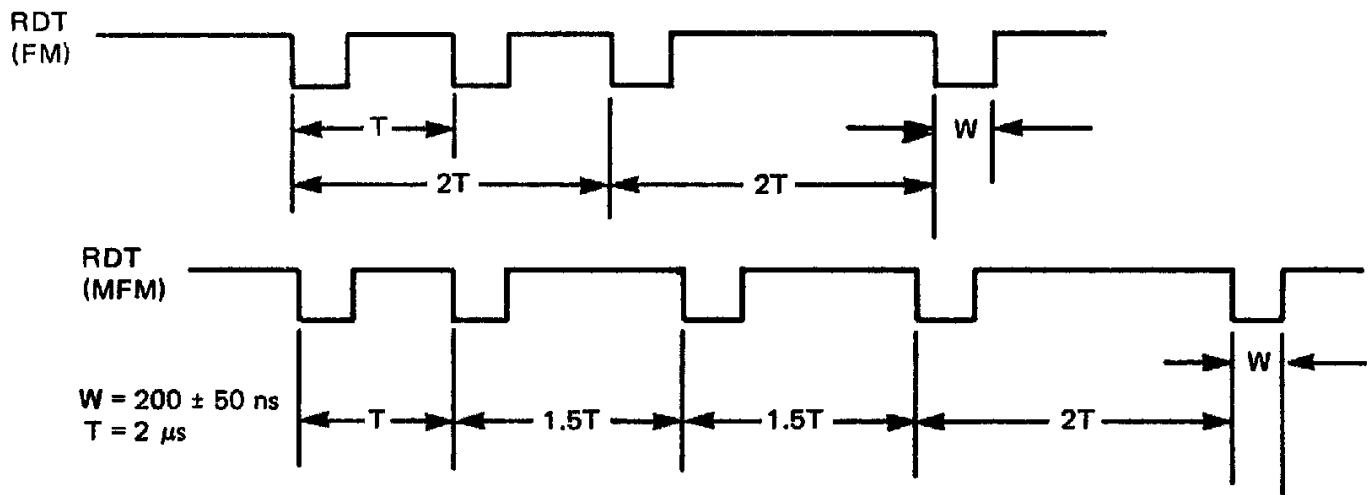

Figure 3-8 Read Data Signal Timing

3.4.7 Write Protect (PRT)

This line is high when the flexible disk does not have a WRITE PROTECT notch and low if the disk has a notch. A notch prevents writing.

3.4.8 Disk Change (DCG)

This signal goes low to signal the controller that the flexible disk has been changed since the disk drive was last selected. The time relationships are shown in Figure 3-9.

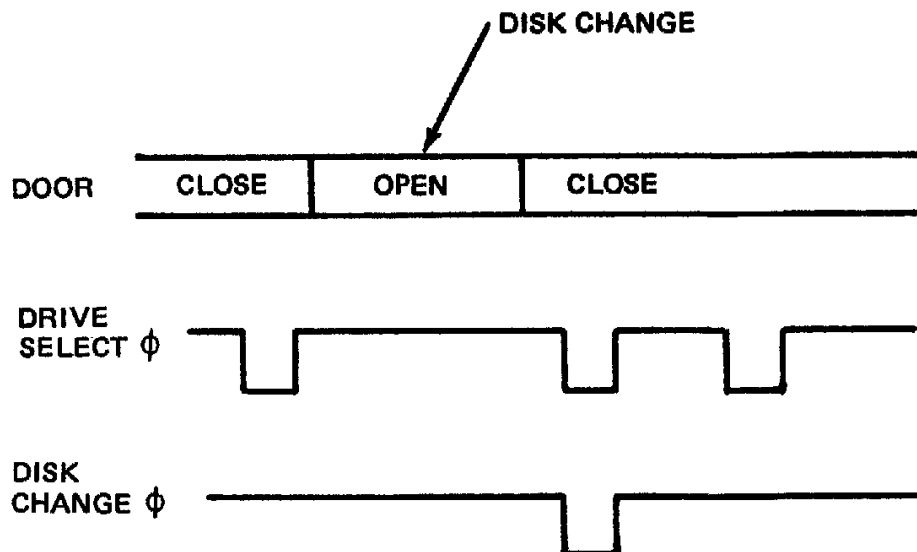

Figure 3-9 Disk Change Signal Timing

3.5 VFO INTERFACE SIGNAL FUNCTIONS

The functions of the optional VFO interface signal are described in the following sections.

3.5.1 Modified Frequency Modulated Mode (MFM)

This line is low when MFM data is to be read or written. The line is high when FM data is to be read or written.

3.5.2 VFO Synchronization (SYC)

This controller signal specifies the operating mode of the VFO circuit. The line is low only when read data is being synchronized.

3.5.3 Standardized Read Data (SRD)

This line conveys STANDARDIZED READ DATA, which is synchronized by the VFO circuit to make it more easily and more reliably read. The time relationship between the STANDARDIZED READ DATA SIGNAL AND THE WINDOW signal is shown in Figure 3-10. (Timing becomes irregular once the data splice point is passed until the VFO is re-synchronized.)

3.5.4 Window (WID)

This signal distinguishes between clock pulses and data output. Phase matching of the WINDOW signal with the STANDARDIZED READ DATA signal is done by the controller.

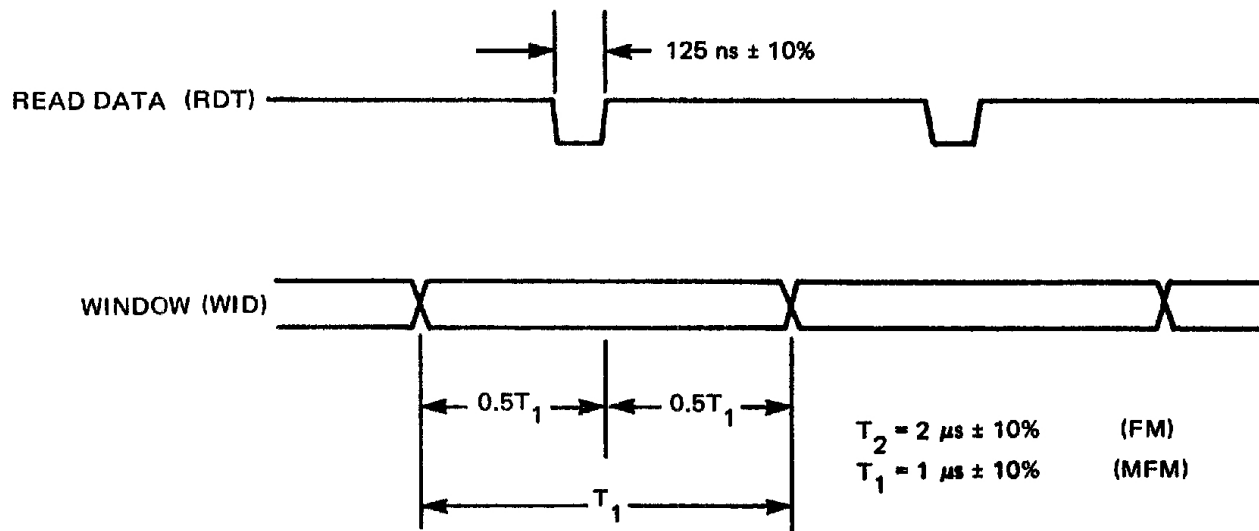

Figure 3-10 Read Data and Window Signal Timing

3.6 INTERFACE TIMING

A description of the interface timing of the disk drive follows.

3.6.1 Power On Sequence

Valid input/output signals are processed by the disk drive 700 ms after the door slot is closed.

3.6.2 Drive Select

Valid input/output signals are processed by the disk drive 500 ns after the appropriate drive select line (DX1, DX2, DX3, or DX4) goes low.

3.6.3 Step and Track 00

The required time relationship between the STEP controller signal and the TRACK 00 output signal is shown in Figure 3-11.

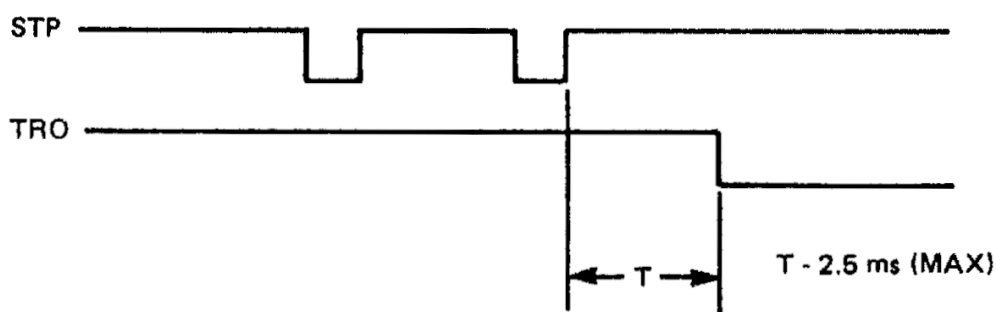
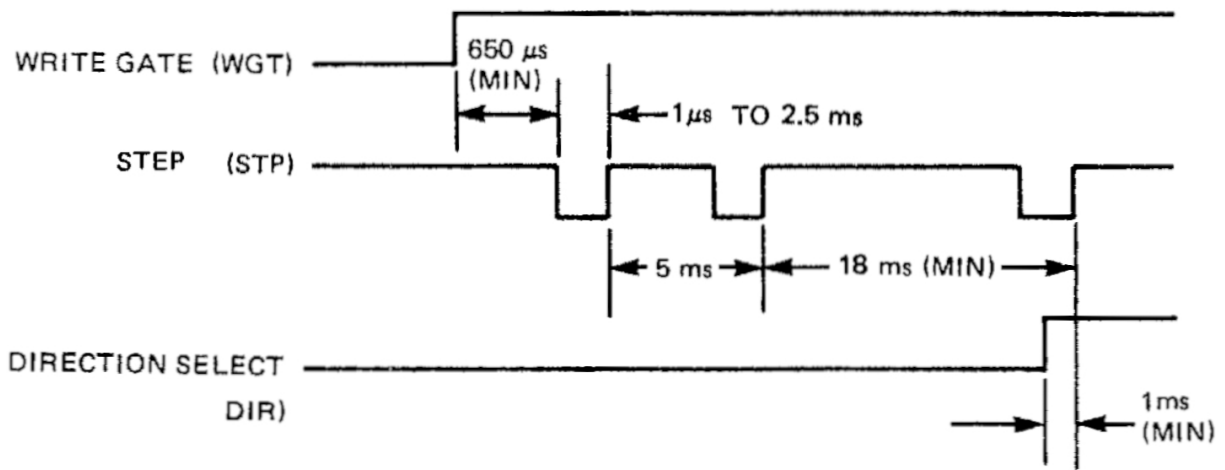

Figure 3-11 Step and Track 00 Signal Timing

3.6.4 Access

The required time relationship among WRITE GATE, STEP, and DIRECTION SELECT controller signals is shown in Figure 3-12.



NOTE: WHEN THE DIRECTION SELECT (DIR) SIGNAL CHANGES, THE STEP PULSE INTERVAL MUST BE MORE THAN 18 ms.

Figure 3-12 Access Timing

3.6.5 Write

The required time relationship of controller signals during a WRITE operation is shown in Figure 3-13.

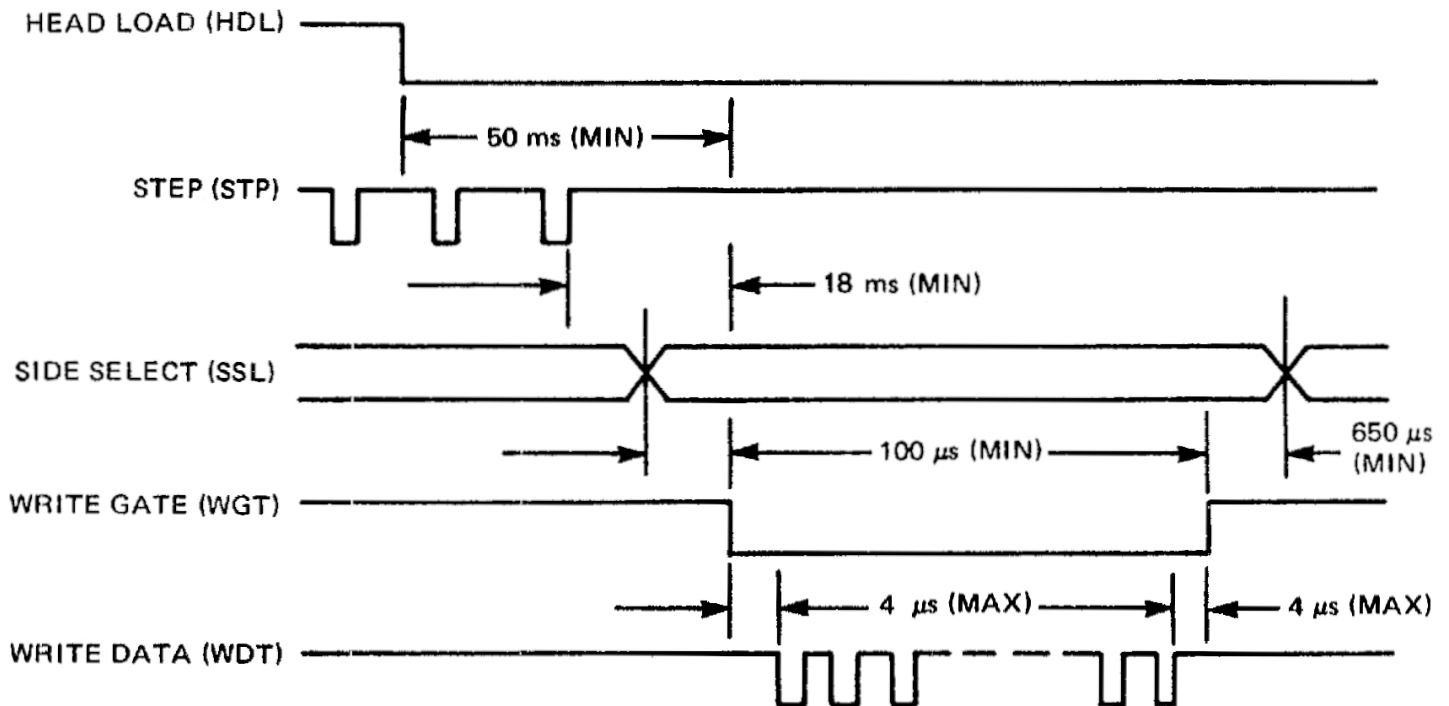

Figure 3-13 Write Timing

3.6.6 Read After Step

The required time relationship of controller signals during a READ AFTER STEP operation is shown in Figure 3-14.

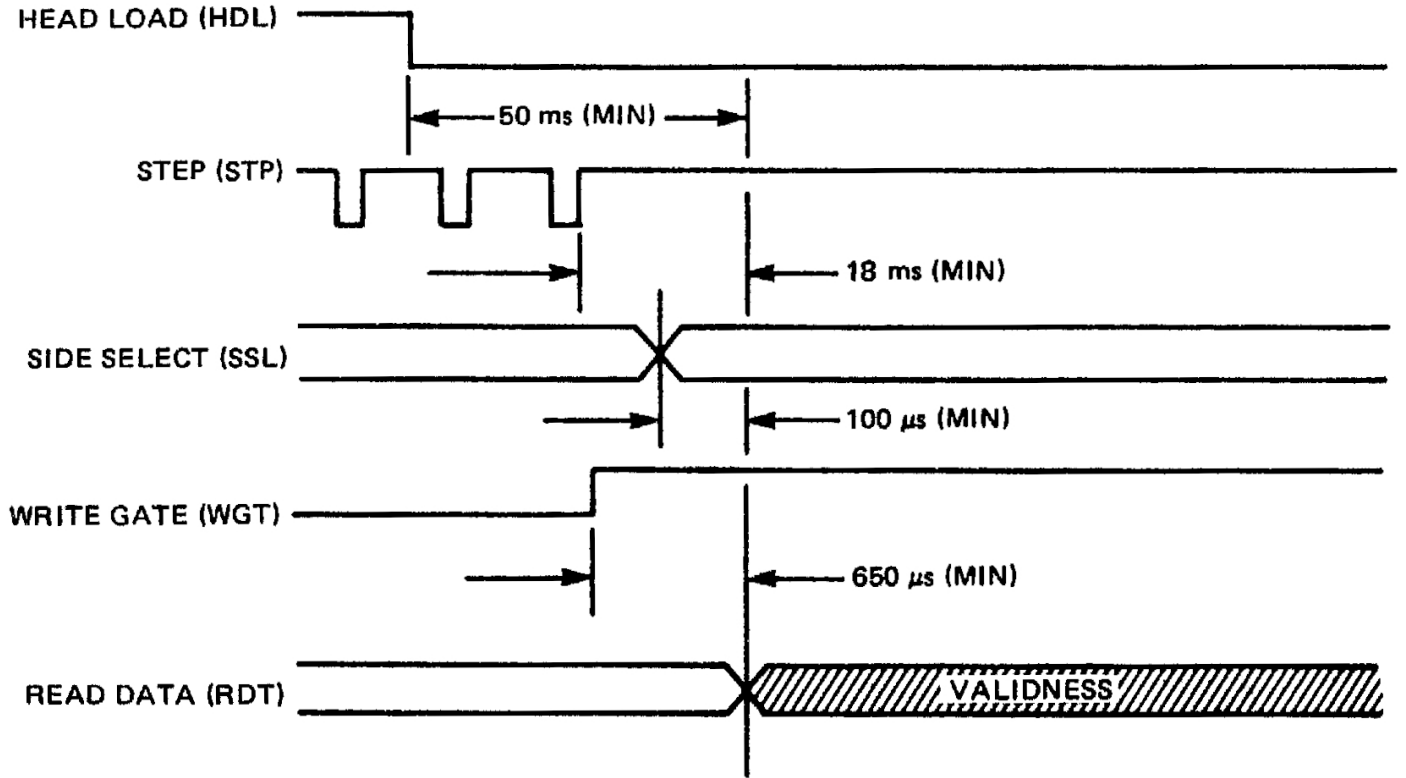

Figure 3-14 Read After Step Timing